

REV.	ECN NO	CONTENT	DATE	ENGINEER
A0				

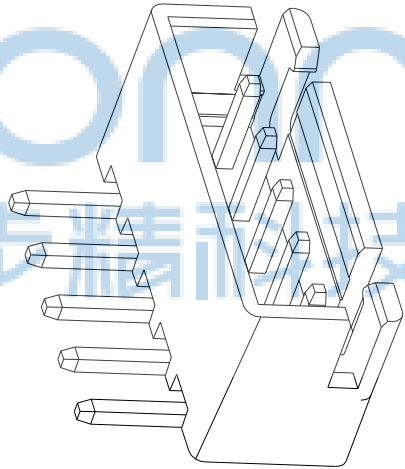
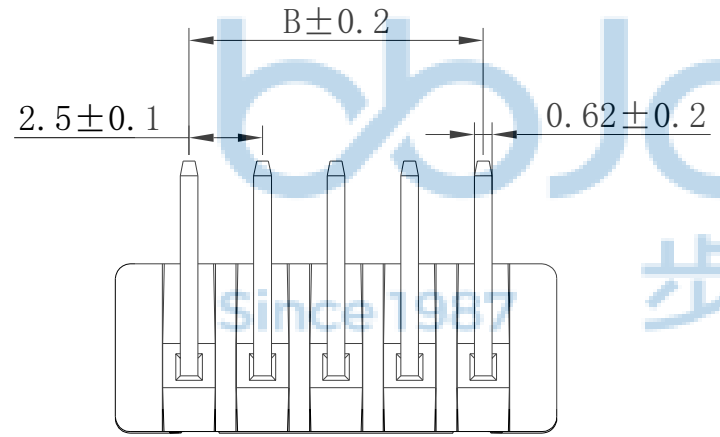
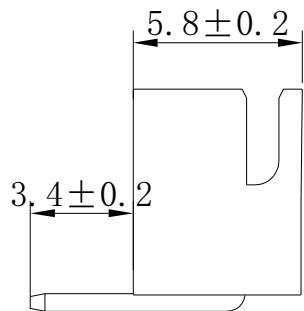
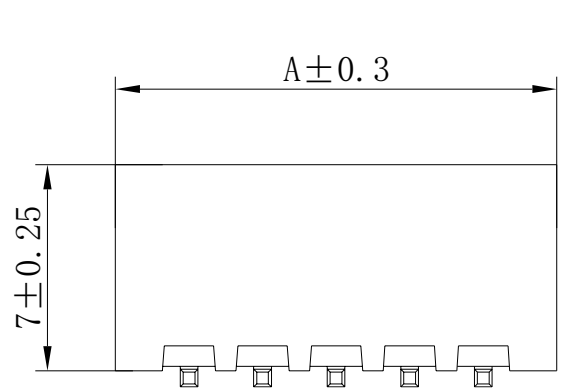

使用温度范围 (Ambient temperature Range): -25° ~ +85°
 适用基板厚度 Applicable PCboard thickness): 1.6mm
 额定电压 (Voltage rating): 250V AC, DC
 额定电流 (Current rating): 3A
 接触电阻 Contact Resistance): 0.02
 绝缘电阻 (Insulation Resistance): 1000M
 耐压 (Withstand Voltage): 1000V/min
 材料 (Material)
 1. 基座: PA66 FV2
 2. 插针: 黄铜

孔位	A	B
2	7.5	2.5
3	10	5.0
4	12.5	7.5
5	15.0	10.0
6	17.5	12.5
7	20.0	15.0
8	22.5	17.5
9	25.0	20.0
10	27.5	22.5
11	30.0	25.0
12	32.5	27.5
13	35.0	30.0
14	37.5	32.5
15	40.0	35.0
16	42.5	37.5

公差	>0-3	>3-18	>18-50	>50-100
范围	±0.15	±0.2	±0.3	±0.5
材料	PA66 94V- 2 (0) or ul			



THIS DOCUMENT IS THE SOLE PROPERTY OF BBJconn Technology Co., Ltd. Corporation AND SHOULD NOT BE USED IN WHOLE OR IN PART WITHOUT PRIOR WRITTEN PERMISSION.

PDWG.NO: 0102-1

DR. SGF

APPD. JM_Zheng

CHKD. LYX

NAME: 深圳市步步精科技有限公司
XH-2AW (2.54-2P) 弯针 米黄色

PJ. NO.: WT.02.61-21-1001

SIZE: A4 DRW NO.:

FINISH: SEE NOTES MAT'L.: SEE NOTES

SCALE: N/A REV.: A0 UNIT: mm PAGE: 1/2

REV.	ECN NO	CONTENT	DATE	ENGINEER
A0				

PE袋规格:***X*** (以实际出货为准)

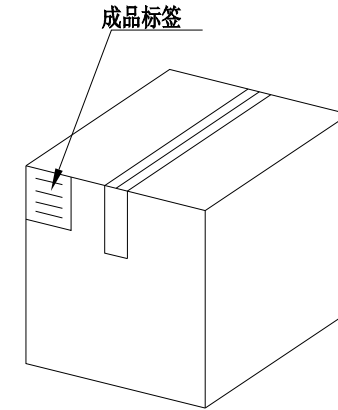
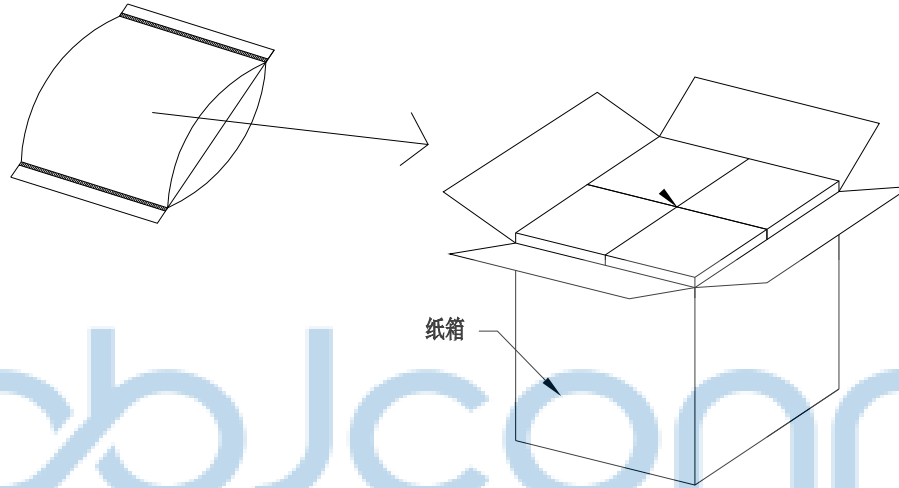

1. 包装要求:

- 1.1 每PE袋包装 2000PCS;
- 1.2 每1袋放一小纸盒;
- 1.3 每20个小纸盒放一个纸箱, 共计40000PCS
- 1.4 纸箱外贴上标签



THIS DOCUMENT IS THE SOLE PROPERTY OF BBJconn Technology Co.,Ltd. Corporation AND SHOULD NOT BE USED IN WHOLE OR IN PART WITHOUT PRIOR WRITTEN PERMISSION.		深圳市步步精科技有限公司 .X: ±0.38 X': ±3' NAME: XH-2AW (2.54-2P) 弯针 米黄色 .XX: ±0.25 .X': ±2' PJ. NO.: WT.02.61-21-1001 .XXX: ±0.13 .XX': ±1' SIZE: A4 DRW NO.: FINISH: SEE NOTES MAT'L.: SEE NOTES SCALE: N/A REV.: A0 UNIT: mm PAGE: 2/2	
APPD.	JM_Zheng		
CHKD.	LYX		
PDWG.NO:	0102-1	DR.	SGF