

REV.	ECN NO	CONTENT	DATE	ENGINEER
AO				

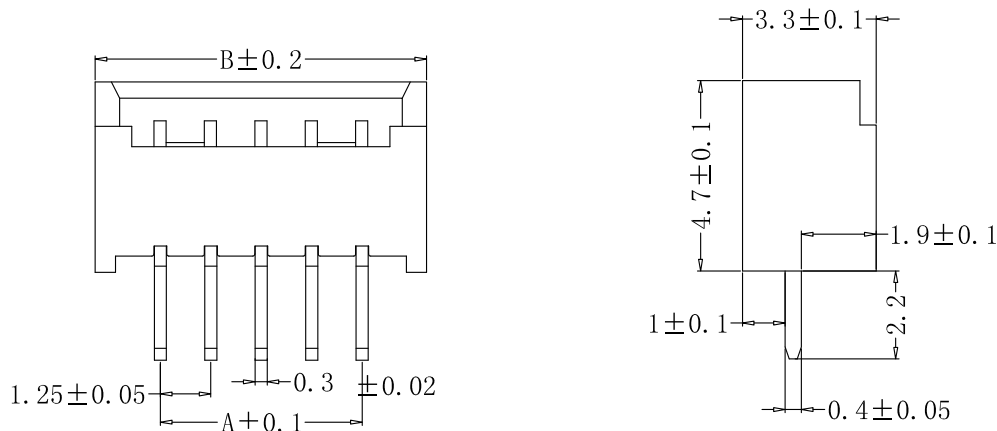

使用温度范围 (Ambient temperature Range): $-25^{\circ} \sim +85^{\circ}$
 适用基板厚度 Applicable PCboard thickness): $0.8\text{mm} \sim 1.6\text{mm}$
 额定电压 (Voltage rating): 50V AC, DC
 额定电流 (Current rating): 1A
 接触电阻 Contact Resistance): $\leq 0.01 \Omega$
 绝缘电阻 (Insulation Resistance): $\geq 500\text{M} \Omega$
 耐压 (Withstand Voltage): 500V/min
 材料 (Material)
 1. 基座: LCP 94V-0 or u1
 2. 插针: 黄铜

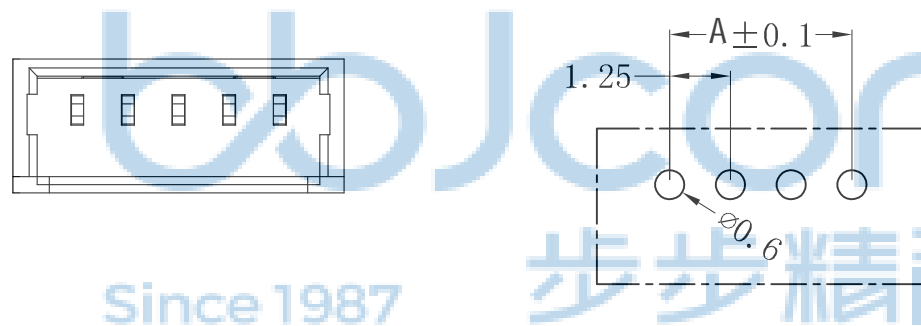

1.25直针	A-mm	B-mm
1.25-2P	1.25mm	4.50mm
1.25-3P	2.50mm	5.75mm
1.25-4P	3.75mm	7.00mm
1.25-5P	5.00mm	8.25mm
1.25-6P	6.25mm	9.50mm
1.25-7P	7.50mm	10.75mm
1.25-8P	8.75mm	12.00mm
1.25-9P	10.00mm	13.25mm
1.25-10P	11.25mm	14.50mm
1.25-11P	12.50mm	15.75mm
1.25-12P	13.75mm	17.00mm
1.25-13P	15.00mm	18.25mm
1.25-14P	16.25mm	19.50mm
1.25-15P	17.50mm	20.75mm
1.25-16P	18.75mm	22.00mm

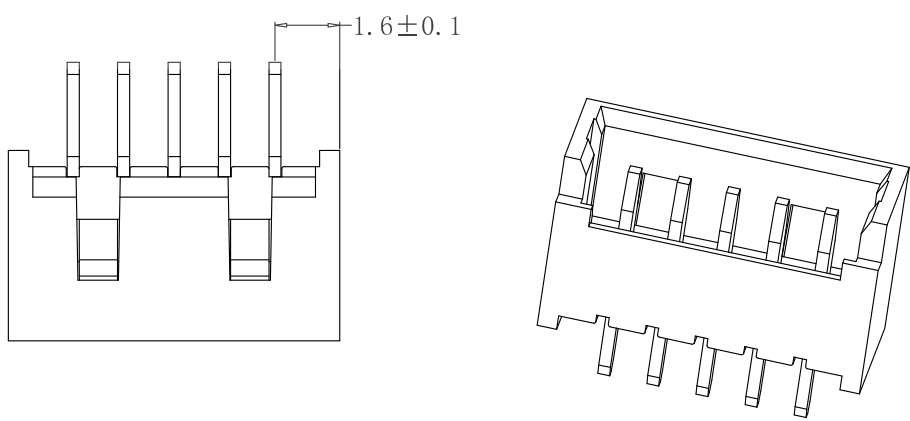

THIS DOCUMENT IS THE SOLE PROPERTY OF BBJconn Technology Co.,Ltd. CORPORATION AND SHOULD NOT BE USED IN WHOLE OR IN PART WITHOUT PRIOR WRITTEN PERMISSION. PDWG.NO: 0102-1

深圳市步步精科技有限公司

.X: ± 0.38 X': $\pm 3'$
 .XX: ± 0.25 .X': $\pm 2'$
 .XXX: ± 0.13 .XX': $\pm 1'$

NAME: 1.25-7A 闭口直针 米黄色

APPD. JM_Zheng PJ. NO.: WT.01.65-11-1002

CHKD. LYX SIZE: A4 DRW NO.:

DR. SGF FINISH: SEE NOTES MAT'L.: SEE NOTES

SCALE: N/A REV.: A3 UNIT: mm PAGE: 1/2

REV.	ECN NO.	CONTENT	DATE	ENGINEER
A0				

PE袋规格:***X*** (以实际出货为准)

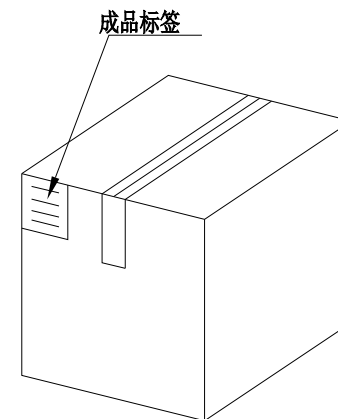
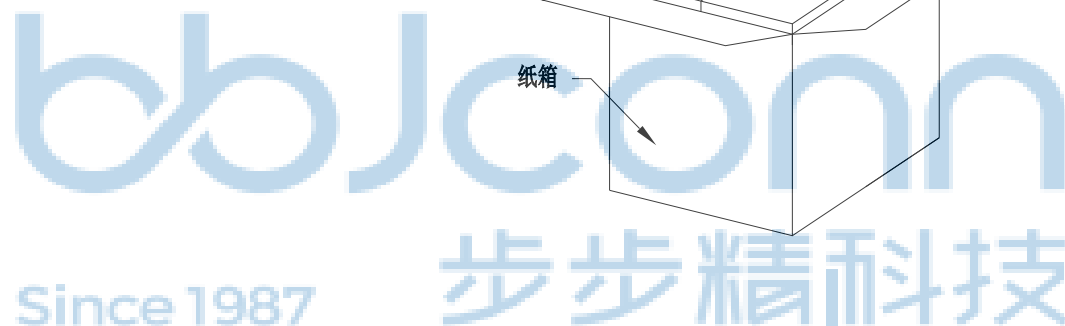
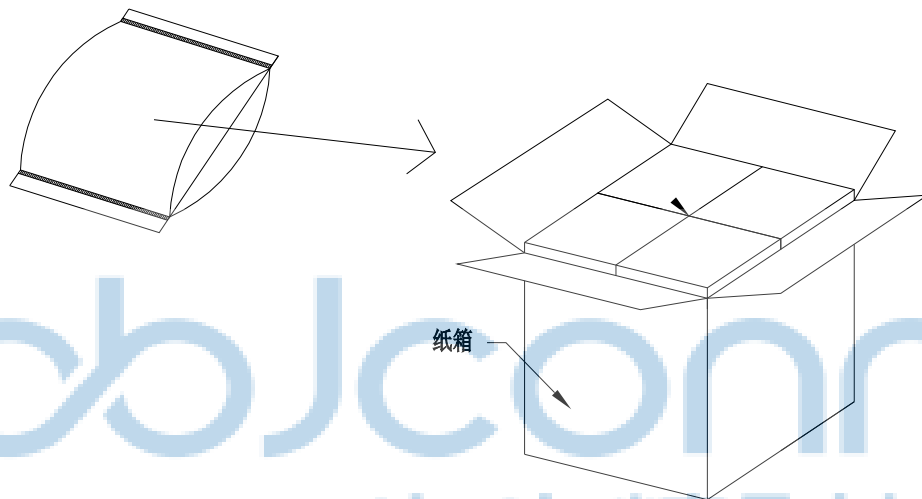

1. 包装要求:

- 1.1 每PE袋包装1000pcs;
- 1.2 每1袋放一小纸盒;
- 1.3 每20个小纸盒放一个纸箱, 共计10000PCS
- 1.4 纸箱外贴上标签



THIS DOCUMENT IS THE SOLE PROPERTY OF BBJconn Technology Co.,Ltd.		深圳市步步精科技有限公司	
Corporation AND SHOULD NOT BE USED IN WHOLE OR IN PART WITHOUT PRIOR WRITTEN PERMISSION.		NAME: 1.25-7A 闭口直针 米黄色	
APPD.	JM_Zheng	PJ. NO.: WT.01.65-11-1002	
CHKD.	LYX	SIZE: A4 DRW NO.:	
PDWG.NO: 0102-1	DR. SGF	FINISH: SEE NOTES MAT'L.: SEE NOTES	
		SCALE: N/A REV.: A3 UNIT: mm PAGE: 2/2	