

REV.	ECN NO	CONTENT	DATE	ENGINEER
A0			2023 20/04	

NOTES:

1. REQUEST OF THE SPECIFICATION:

- 1.1 CONTACT CURRENT RATING: 1A;
- 1.2 CONTACT RESISTANCE: 100 mΩ MAX.;
- 1.3 INSULATION RESISTANCE: 100MΩ MIN.;
- 1.4 DIELECTRIC WITHSTANDING: 500V AC MIN.;
- 1.5 DURABILITY: 5,000 CYCLES MIN.;
- 1.6 CONNECTOR MATING FORCES: 29.8N (3.00Kgf) MAX.;
- 1.7 CONNECTOR UNMATING FORCES: 2.98N(0.30Kgf) MIN.;

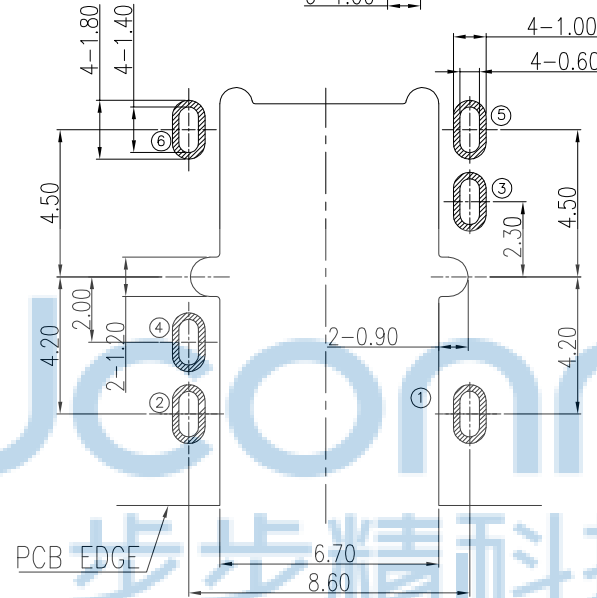
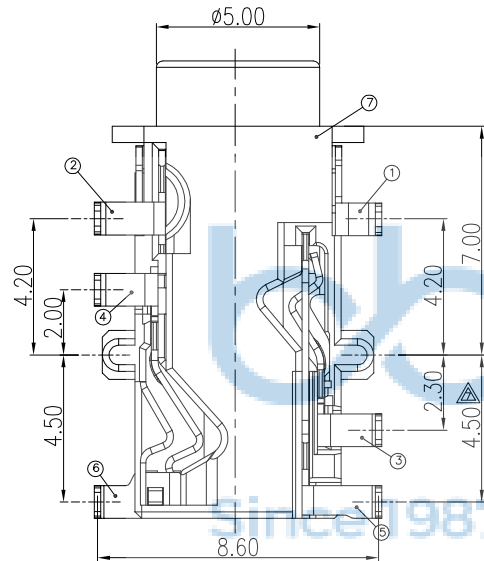
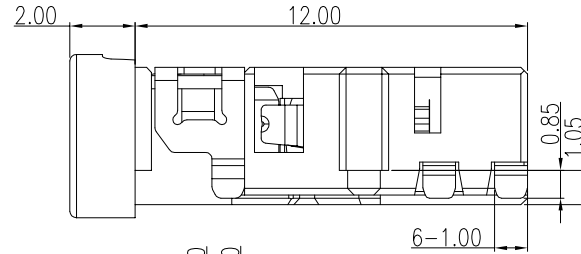
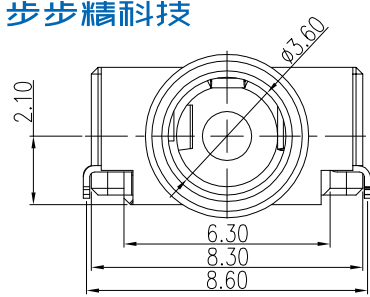

RECOMMENDED PCB LAYOUT(TOP VIEW)  
(GENERAL TOLERANCE:±0.05)

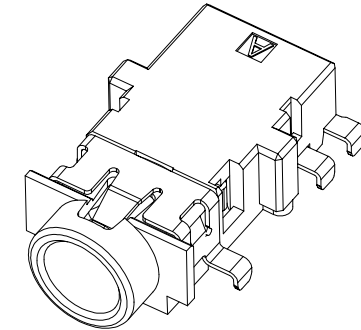

3D VIEW

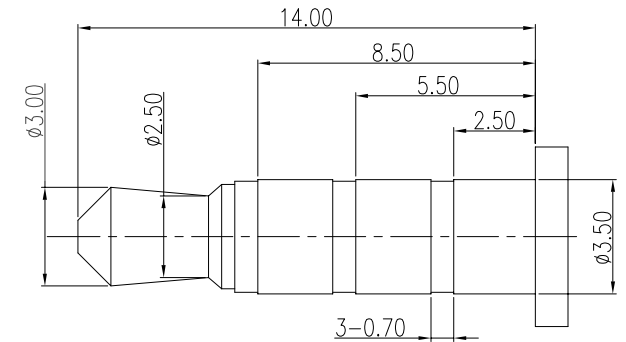

(ø3.50mm 4 POLE PLUG DETAIL DRAWING)

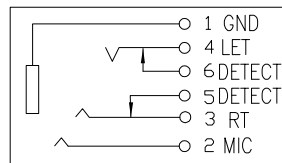
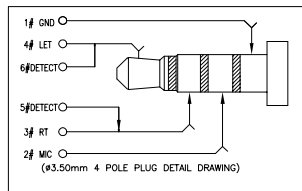

SCHEMATIC



ITEM	NAME	Q'TY	DESCRIPTION	NOTE
7	HOUSING	1	HIGHT TEMPERATURE PLASTIC COLOR BLACK	
6	TERMINAL 6#	1	PHOSPHOR BRONZE; NICKEL UNDER PLATING OVERALL;GOLD FLASH ON SOLDER AREA	T=0.20
5	TERMINAL 5#	1	PHOSPHOR BRONZE; NICKEL UNDER PLATING OVERALL;GOLD FLASH ON SOLDER AREA	T=0.20
4	TERMINAL 4#	1	PHOSPHOR BRONZE; NICKEL UNDER PLATING OVERALL;GOLD FLASH ON SOLDER AREA ;GOLD FLASH ON CONTACT AREA	T=0.20
3	TERMINAL 3#	1	PHOSPHOR BRONZE; NICKEL UNDER PLATING OVERALL;GOLD FLASH ON SOLDER AREA ;GOLD FLASH ON CONTACT AREA	T=0.20
2	TERMINAL 2#	1	PHOSPHOR BRONZE; NICKEL UNDER PLATING OVERALL;GOLD FLASH ON SOLDER AREA ;GOLD FLASH ON CONTACT AREA	T=0.20
1	TERMINAL 1#	1	PHOSPHOR BRONZE; NICKEL UNDER PLATING OVERALL;GOLD FLASH ON SOLDER AREA ;GOLD FLASH ON CONTACT AREA	T=0.20

THIS DOCUMENT IS THE  
SOLE PROPERTY OF  
BBJconn Technology Co.,Ltd.  
Corporation AND SHOULD  
NOT BE USED IN WHOLE  
OR IN PART WITHOUT  
PRIOR WRITTEN PERMISSION.  
PDWG:NO: 0076-1

**深圳市步步精科技有限公司**

NAME:  
3.5耳机座 有头 沉板1.0 六脚插 四节 (PJ35A083-F06G1BR-F)

APPD. JM\_Zheng 23/05/02

CHKD. LYX 23/05/02

DR. SGF 23/05/02

PJ. NO.: PJ.03.22-01-3020

SIZE: A4 DRW NO.:

FINISH: SEE NOTES MAT'L.: SEE NOTES

SCALE: N/A REV.: A0 UNIT: mm PAGE: 1/1

REV.	ECN NO.	CONTENT	DATE	ENGINEER
A0			2023 20/04	

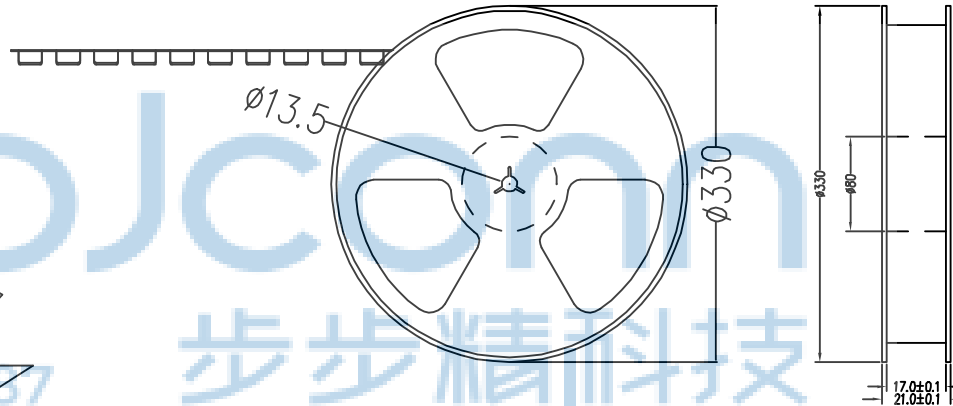
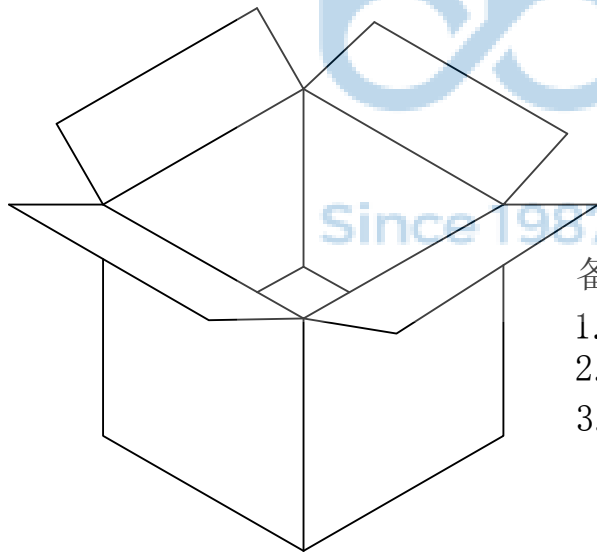
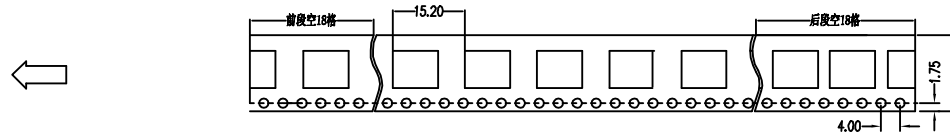
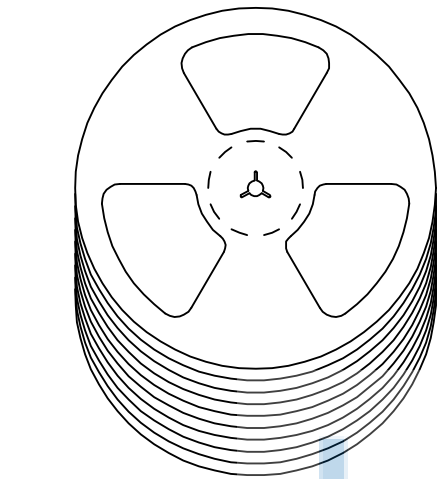

备注:

1. 包装数量: 1000/PCS/卷, 10卷/箱或15卷/箱。
2. 包装袋长度: 每卷前后各空10-20个空格, 中间包装。
3. 材质:  
载体: 聚丙烯 (PS), 阻抗 $10^{6-9} \Omega$   
上带: 聚乙烯 (PET), 阻抗 $10^{6-11} \Omega$   
卷盘: 聚苯乙烯。

纸箱规格: 345\*345\*23MM

纸箱规格: 345\*345\*35MM

THIS DOCUMENT IS THE SOLE PROPERTY OF BBJconn Technology Co.,Ltd. Corporation AND SHOULD NOT BE USED IN WHOLE OR IN PART WITHOUT PRIOR WRITTEN PERMISSION.		深圳市步步精科技有限公司 .X: ±0.38 .X': ±3" .XX: ±0.25 .X": ±2" .XXX: ±0.13 .XX': ±1"		NAME: 3.5耳机座 有头 沉板1.0 六脚插 四节 (PJ35A083-F06G1BR-F)	
APPD.	JM_Zheng	23/05'02	PJ. NO.: PJ.03.22-01-3020		
CHKD.	LYX	23/05'02	SIZE: A4   DRW NO.:		
PDWG.NO:	0076-1	DR.	SGF	23/05'02	FINISH: SEE NOTES   MAT'L.: SEE NOTES SCALE: N/A   REV.: A0   UNIT: mm   PAGE: 1/1