

NOTES:

1. MATERIAL: SEE "TABLE 1".
2. FINISH: SEE "TABLE 1".
3. ELECTRICAL:
 - 3.1. VOLTAGE RATING: 12 VAC RMS.
 - 3.2. CURRENT RATING: 1 AMP.
 - 3.3. CONTACT RESISTANCE: 50mΩ Max.(Initial), 100mΩ Max.(After Life test).
 - 3.4. INSULATION RESISTANCE: 100 MΩ Min., 500VDC.(Initial), 50 MΩ Min., 500VDC.(After Humidity test)
 - 3.5. WITHSTAND VOLTAGE: 500 VAC RMS 50(60)Hz, 1 minute.
4. INITIAL:
 - 4.1. INSERTION FORCE: 1.0~2.5Kgf. (AFTER LIFE:0.4~2.0Kgf).
 - 4.2. WITHDRAWAL FORCE: 0.6~1.8Kgf. (AFTER LIFE:0.4~2.0Kgf).
5. OPERATING LIFE: 5000 CYCLES MIN..

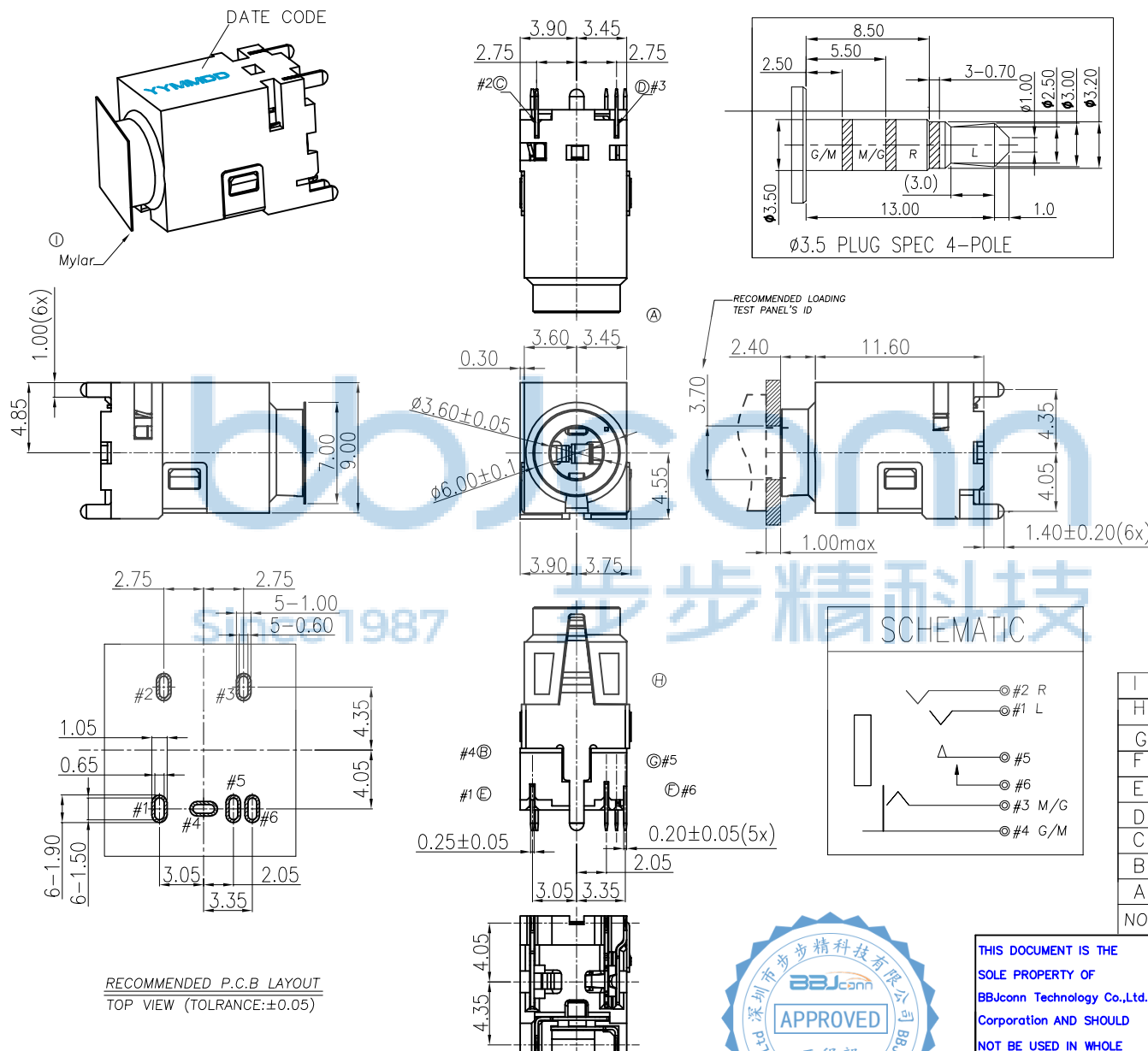

I	Mylar	1	PI	Yellow
H	Separator	1	PPA	Black,UL 94V-0
G	Transfer terminal	1	C5210 0.2T	Gold Flash on contact area, Gold Flash solder area, ALL Over 50u" Nickel
F	Make terminal	1	C5210 0.2T	
E	Tip-Spring	1	SUS301-1/2H 0.25T	G/F Or Au 30u" on contact area, Gold Flash solder area, ALL Over 50u" Nickel
D	Ring B	1	C5210 0.2T	
C	Ring A	1	C5210 0.2T	
B	Earth-Spring	1	C5210 0.2T	
A	Body	1	PA10T	Black,UL 94V-0
NO.	PART NAME	QTY	MATERIAL	DESCRIPTION



THIS DOCUMENT IS THE SOLE PROPERTY OF BBJconn Technology Co.,Ltd. Corporation AND SHOULD NOT BE USED IN WHOLE OR IN PART WITHOUT PRIOR WRITTEN PERMISSION.

PDWG.NO: 0079-2

深圳市步步精科技有限公司

NAME: 3.5耳机座
ST-35108-T14-MY-TR 有头 六脚插 三节

APPD. JM_Zheng 23/05/02

CHKD. LYX 23/05/02

DR. SGF 23/05/02

PJ. NO.: PJ.02.22-01-1002

SIZE: A4 DRW NO.:

FINISH: SEE NOTES MAT'L.: SEE NOTES

SCALE: N/A REV.: A0 UNIT: mm PAGE: 1/1

REV.	ECN NO	CONTENT	DATE	ENGINEER
A0			2023 20/04	

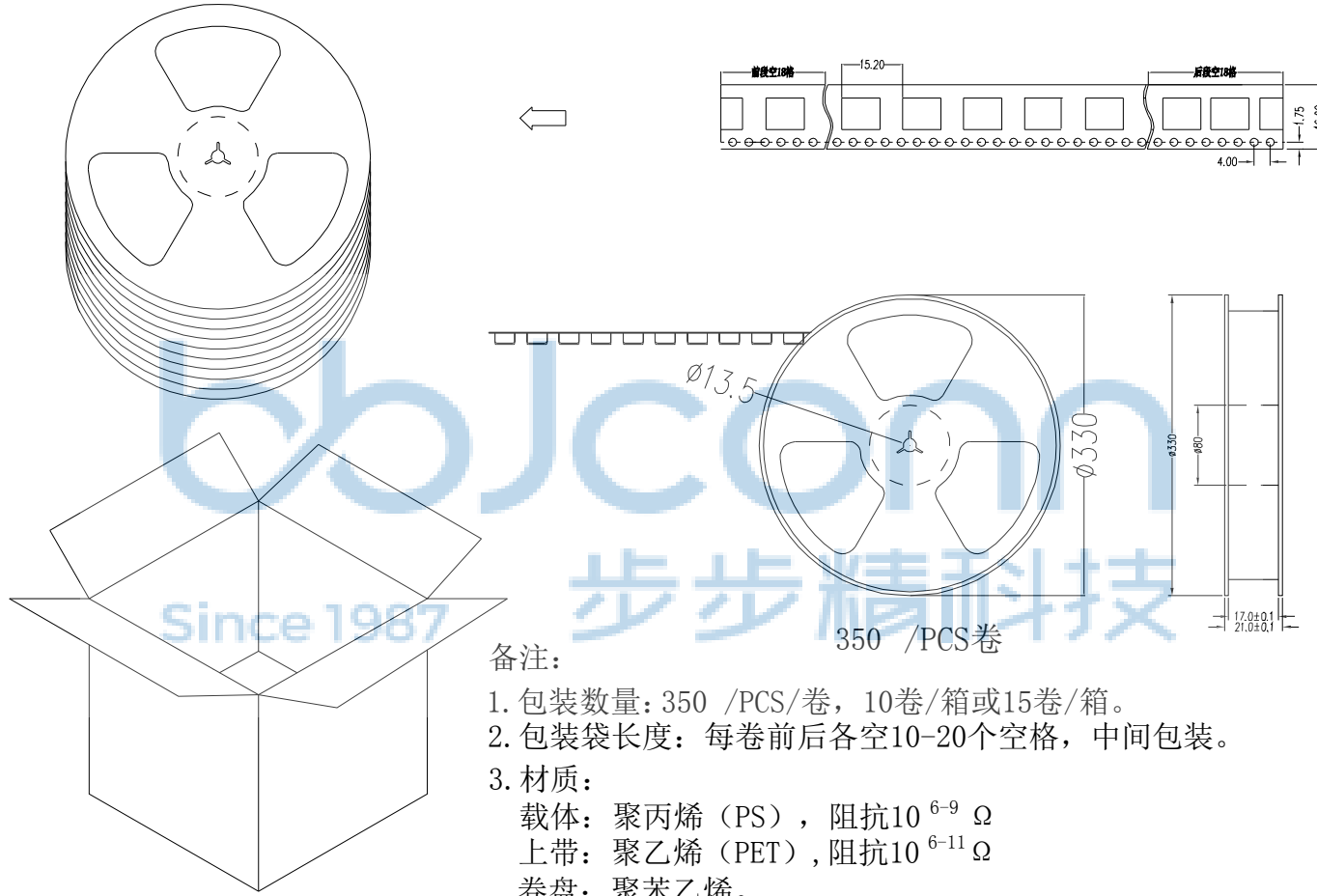

备注:

1. 包装数量: 350 /PCS/卷, 10卷/箱或15卷/箱。
2. 包装袋长度: 每卷前后各空10-20个空格, 中间包装。
3. 材质:
载体: 聚丙烯 (PS), 阻抗 $10^{6-9} \Omega$
上带: 聚乙烯 (PET), 阻抗 $10^{6-11} \Omega$
卷盘: 聚苯乙烯。

纸箱规格: 345*345*23MM
纸箱规格: 345*345*35MM



THIS DOCUMENT IS THE SOLE PROPERTY OF BBJconn Technology Co., Ltd. Corporation AND SHOULD NOT BE USED IN WHOLE OR IN PART WITHOUT PRIOR WRITTEN PERMISSION.		深圳市步步精科技有限公司 .X: ±0.38 .X': ±3' .XX: ±0.25 .X'': ±2' .XXX: ±0.13 .XX': ±1'		NAME: 3.5耳机座 ST-35108-T14-MY-TR 有头 六脚插 三节	
APPD.	JM_Zheng	23/05'02	PJ. NO.: PJ.02.22-01-1002 SIZE: A4 DRW NO.:		
CHKD.	LYX	23/05'02	FINISH: SEE NOTES MAT'L.: SEE NOTES SCALE: N/A REV.: A0 UNIT: mm PAGE: 1/1		
PDWG.NO:	0079-2	DR.	SGF	23/05'02	