

REV.	ECN NO	CONTENT	DATE	ENGINEER
A0			2023 20/04	

- NOTES
- CURRENT RATING: 1A.
 - CONTACT RESISTANCE: 100mΩ MAX.
 - INSULATION RESISTANCE: 100MΩ MIN.
 - DIELECTRIC WITHSTANDING: 500V AC MIN.
 - DURABILITY: 5000 CYCLES MIN.
 - CONNECTOR MATING FORCES: 3~30N.
 - CONNECTOR UNMATING FORCES: 3~30N.
 - OPERATING TEMPERATURE: -25°C TO +85°C.

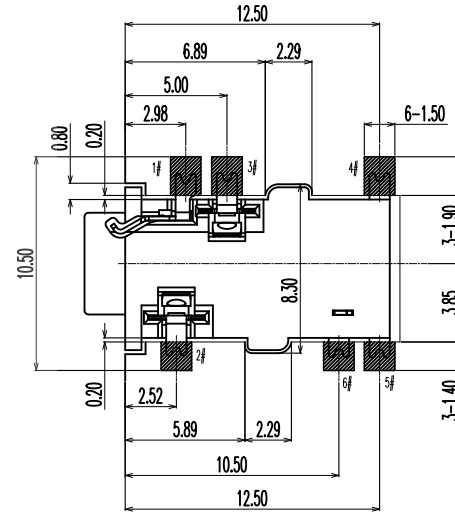

PCB LAYOUT
TOLERANCE: ±0.05

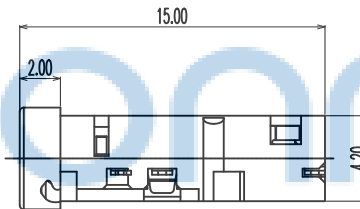
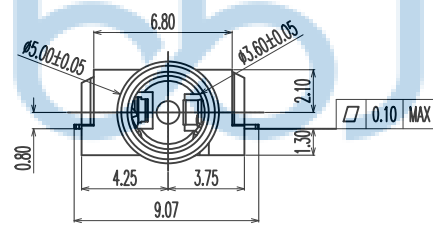
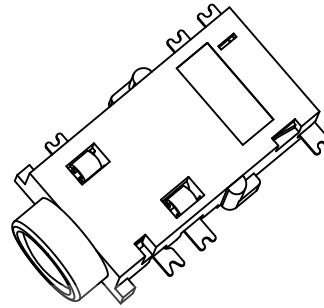
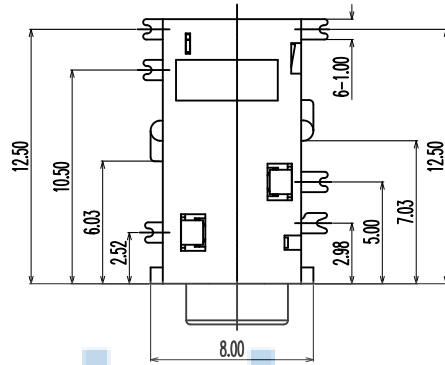
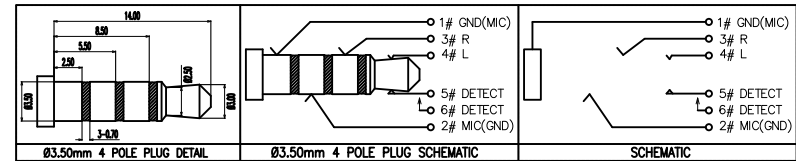
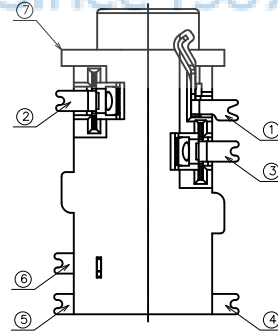

ITEM	NAME	Q'TY	DESCRIPTION
⑦	HOUSING	1	HIGH TEMPERATURE PLASTICS; BLACK
⑥	TERMINAL 6#	1	BRASS; NICKEL UNDERPLATING OVERALL, GOLD PLATING
	INSULATION	1	HIGH TEMPERATURE PLASTICS; BLACK
⑤	TERMINAL 5#	1	PHOSPHOR BRONZE; NICKEL UNDERPLATING OVERALL, GOLD PLATING
④	TERMINAL 4#	1	PHOSPHOR BRONZE; NICKEL UNDERPLATING OVERALL, GOLD PLATING
③	TERMINAL 3#	1	STAINLESS STEEL; NICKEL UNDERPLATING OVERALL, GOLD PLATING
②	TERMINAL 2#	1	STAINLESS STEEL; NICKEL UNDERPLATING OVERALL, GOLD PLATING
①	TERMINAL 1#	1	PHOSPHOR BRONZE; NICKEL UNDERPLATING OVERALL, GOLD PLATING

THIS DOCUMENT IS THE SOLE PROPERTY OF BBJconn Technology Co.,Ltd. Corporation AND SHOULD NOT BE USED IN WHOLE OR IN PART WITHOUT PRIOR WRITTEN PERMISSION.

PDWG.NO: 0076-1

DR. SGF 23/05/02

APPD. JM_Zheng 23/05/02

CHKD. LYX 23/05/02

FINISH: SEE NOTES MAT'L.: SEE NOTES

SCALE: N/A REV.: A0 UNIT: mm PAGE: 1/1

深圳市步步精科技有限公司

NAME: 3.5耳机座 有头 沉板1.3 六脚贴 四节 (PJ35A017-F06G1BF-B)

PJ. NO.: PJ.03.22-01-3031

SIZE: A4 DRW NO.:

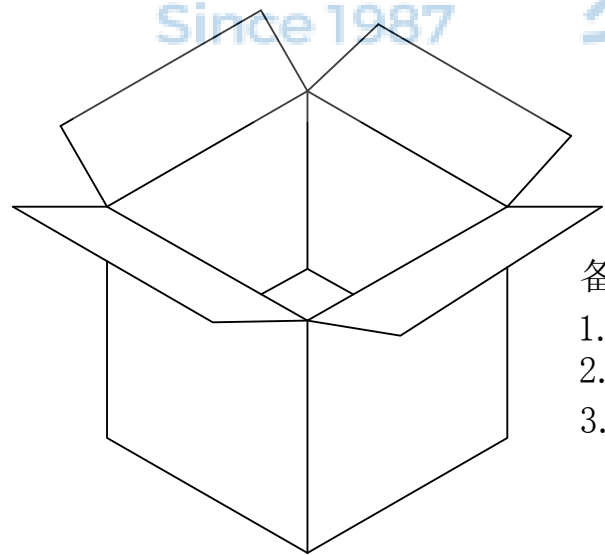
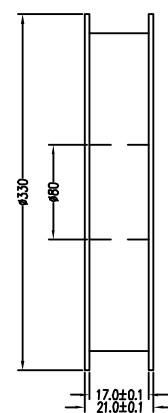
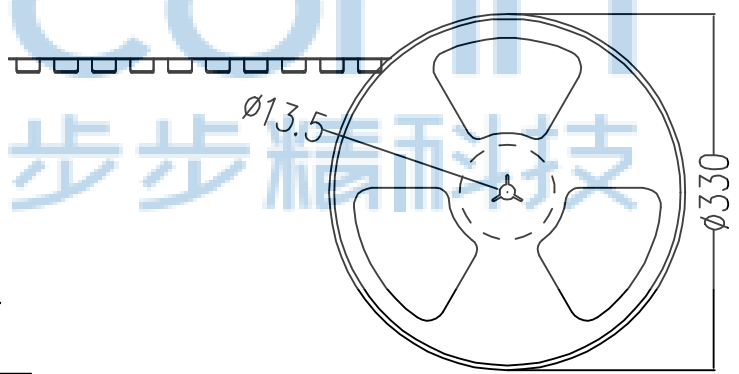
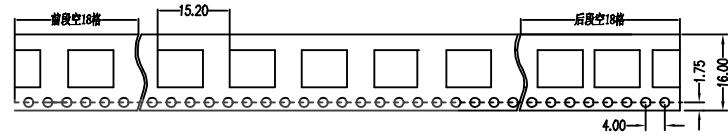
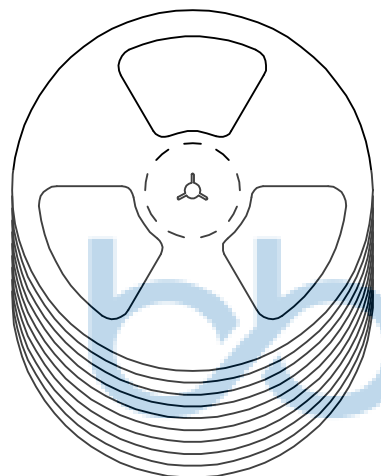

备注:

1. 包装数量: 1000/PCS/卷, 10卷/箱或15卷/箱。
2. 包装袋长度: 每卷前后各空10-20个空格, 中间包装。
3. 材质:
 载体: 聚丙烯 (PS), 阻抗 $10^{6-9} \Omega$
 上带: 聚乙烯 (PET), 阻抗 $10^{6-11} \Omega$
 卷盘: 聚苯乙烯。

纸箱规格: 345*345*23MM
 纸箱规格: 345*345*35MM

THIS DOCUMENT IS THE SOLE PROPERTY OF BBJconn Technology Co.,Ltd. Corporation AND SHOULD NOT BE USED IN WHOLE OR IN PART WITHOUT PRIOR WRITTEN PERMISSION.		深圳市步步精科技有限公司	
.X: ±0.38 .XX: ±0.25 .XXX: ±0.13		X': ±3" X'': ±2" XX': ±1"	
APPD.	JM_Zheng	23/05'02	NAME: 3.5耳机座 有头 沉板1.3 六脚贴 四节 (PJ35A017-F06G1BF-B)
CHKD.	TSP	23/05'02	PJ. NO.: PJ.03.22-01-3031 SIZE: A4 DRW NO.:
DR.	SGF	23/05'02	FINISH: SEE NOTES MAT'L.: SEE NOTES SCALE: N/A REV.: A3 UNIT: mm PAGE: 1/1
PDWG.NO: 0076-1			