

REV.	ECN NO.	CONTENT	DATE	ENGINEER
AO			2023 20/04	

- NOTES:
1. REQUEST OF THE SPECIFICATION:
1.1 CONTACT CURRENT RATING: 1A;
1.2 CONTACT RESISTANCE: 100 mΩ MAX.;
1.3 INSULATION RESISTANCE: 100MΩ MIN.;
1.4 DIELECTRIC WITHSTANDING: 500V AC MIN.;
1.5 DURABILITY: 5,000 CYCLES MIN.;
1.6 CONNECTOR MATING FORCES: 29.8N (3.00Kgf) MAX.;
1.7 CONNECTOR UNMATING FORCES: 2.98N(0.30Kgf) MIN.;

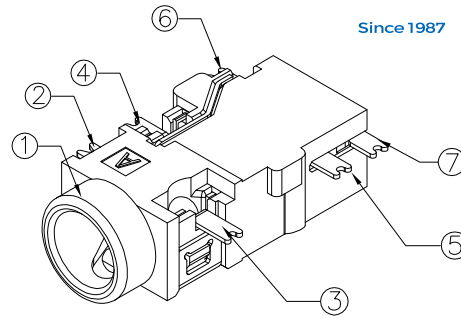

3D VIEW

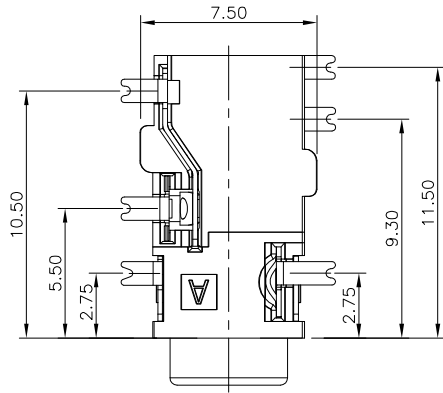
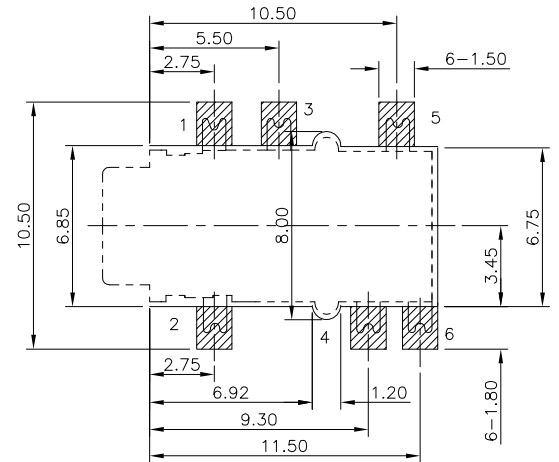
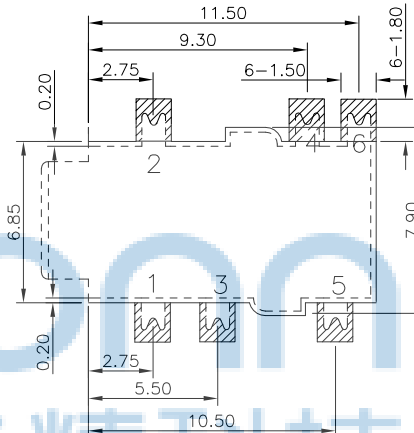
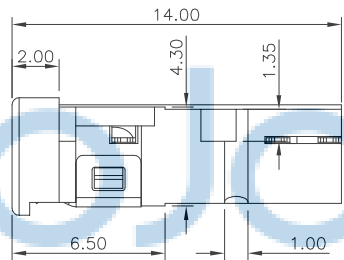
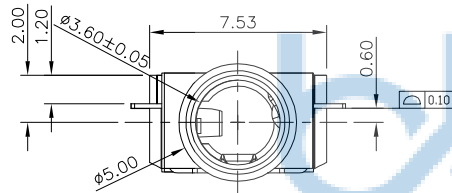

P.C.B LAYOUT TOP VIEW 反贴

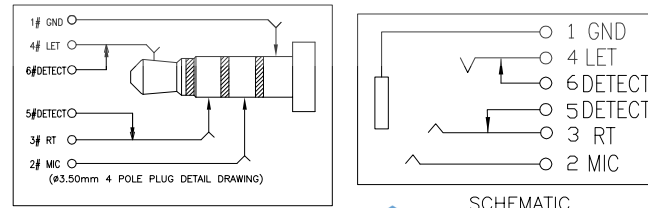
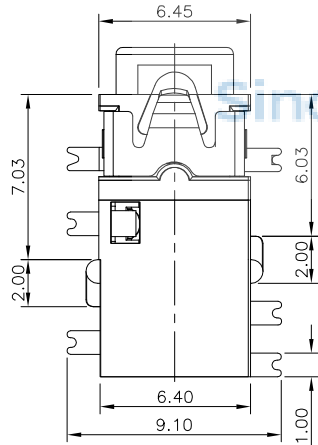

SCHEMATIC

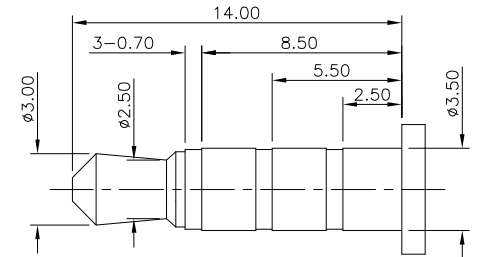

(ø3.50mm 4 POLE PLUG DETAIL DRAWING)



ITEM	NAME	Q'TY	DESCRIPTION	NOTE
7	TERMINAL 6#	1	STAINLESS STEEL; NICKEL UNDER PLATING OVERALL,GOLD FLASH ON SOLDER AREA	T=0.20
6	TERMINAL 5#	1	STAINLESS STEEL; NICKEL UNDER PLATING OVERALL,GOLD FLASH ON SOLDER AREA	T=0.20
5	TERMINAL 4#	1	PHOSPHOR BRONZE; NICKEL UNDER PLATING OVERALL,GOLD FLASH ON CONTACT AREA	T=0.20
4	TERMINAL 3#	1	PHOSPHOR BRONZE; NICKEL UNDER PLATING OVERALL,GOLD FLASH ON SOLDER AREA ;GOLD FLASH ON CONTACT AREA	T=0.20
3	TERMINAL 2#	1	PHOSPHOR BRONZE; NICKEL UNDER PLATING OVERALL,GOLD FLASH ON SOLDER AREA ;GOLD FLASH ON CONTACT AREA	T=0.20
2	TERMINAL 1#	1	STAINLESS STEEL; THE BOTTOM OF THE NICKEL; THE WHOLE GOLD FLASH PLATING.	T=0.20
1	HOUSING	1	HIGHT TEMPERATURE PLASTIC COLOR BLACK	

THIS DOCUMENT IS THE
SOLE PROPERTY OF
BBJconn Technology Co.,Ltd.
Corporation AND SHOULD
NOT BE USED IN WHOLE
OR IN PART WITHOUT
PRIOR WRITTEN PERMISSION.

深圳市步步精科技有限公司

NAME:	3.5耳机座 有头 沉板1.4 六脚贴 四节 (PJ35A028-F06G1BR-A)		
APPD.	JM_Zheng	23/05/02	PJ. NO.: PJ.03.22-01-3027
CHKD.	LYX	23/05/02	SIZE: A4 DRW NO.:
PDWG.NO:	0076-1	DR.	SGF 23/05/02
FINISH: SEE NOTES		MAT'L.: SEE NOTES	
SCALE: N/A	REV.: A0	UNIT: mm	PAGE: 1/1

REV.	ECN NO.	CONTENT	DATE	ENGINEER
AO			2023 20/04	

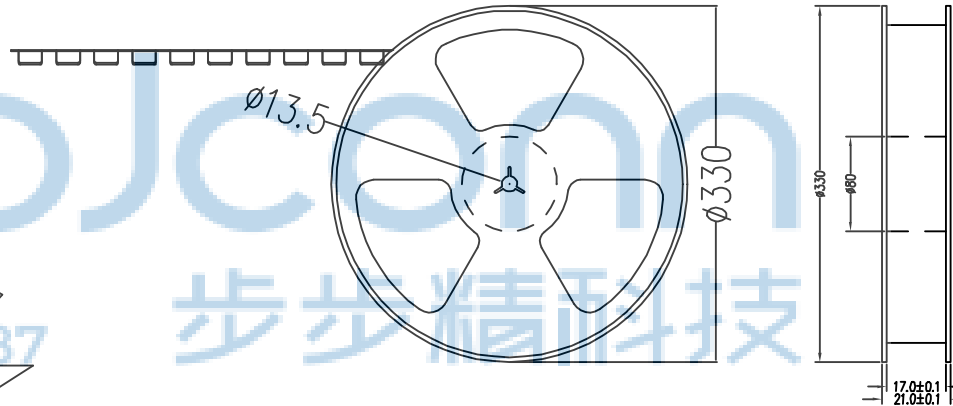
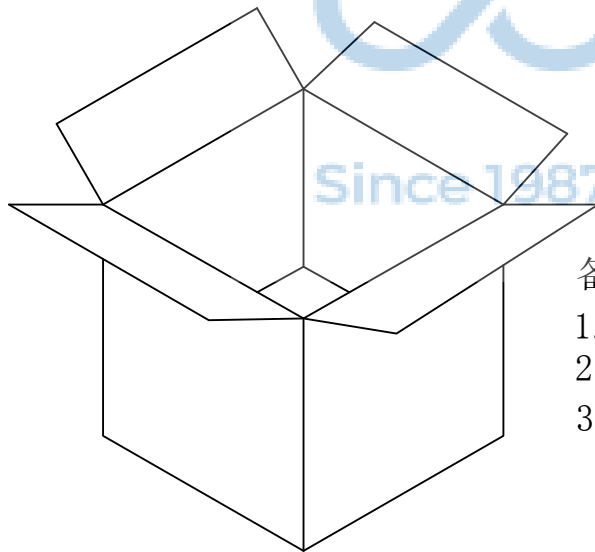
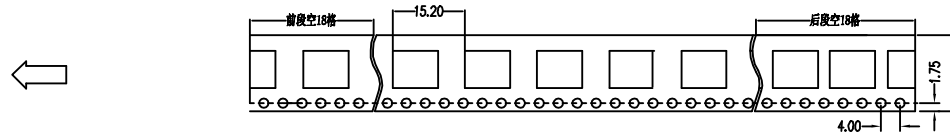
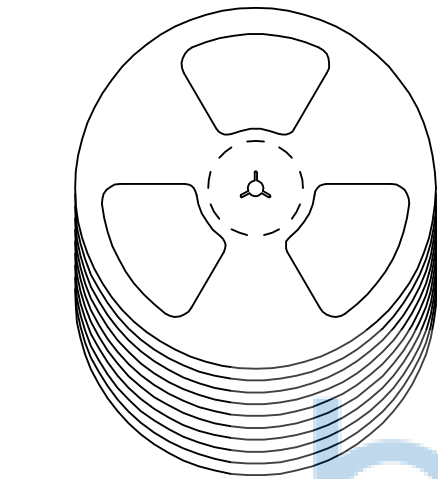

备注:

1. 包装数量: 1000/PCS/卷, 10卷/箱或15卷/箱。
2. 包装袋长度: 每卷前后各空10-20个空格, 中间包装。
3. 材质:
载体: 聚丙烯 (PS), 阻抗 $10^{6-9} \Omega$
上带: 聚乙烯 (PET), 阻抗 $10^{6-11} \Omega$
卷盘: 聚苯乙烯。

纸箱规格: 345*345*23MM

纸箱规格: 345*345*35MM

THIS DOCUMENT IS THE SOLE PROPERTY OF BBJconn Technology Co.,Ltd. Corporation AND SHOULD NOT BE USED IN WHOLE OR IN PART WITHOUT PRIOR WRITTEN PERMISSION.		深圳市步步精科技有限公司	
.X: ±0.38 .XX: ±0.25 .XXX: ±0.13		X': ±3" .X": ±2" .XX": ±1"	
APPD.	JM_Zheng	23/05'02	NAME: 3.5耳机座 有头 沉板1.4 六脚贴 四节 (PJ35A028-F06G1BR-A)
CHKD.	LYX	23/05'02	PJ. NO.: PJ.03.22-01-3027
DR.	SGF	23/05'02	SIZE: A4 DRW NO.:
PDWG.NO: 0076-1		FINISH: SEE NOTES MAT'L.: SEE NOTES	
		SCALE: N/A REV.: A0 UNIT: mm PAGE: 1/1	