

REV.	ECN NO	CONTENT	DATE	ENGINEER
A0			2023 20/04	

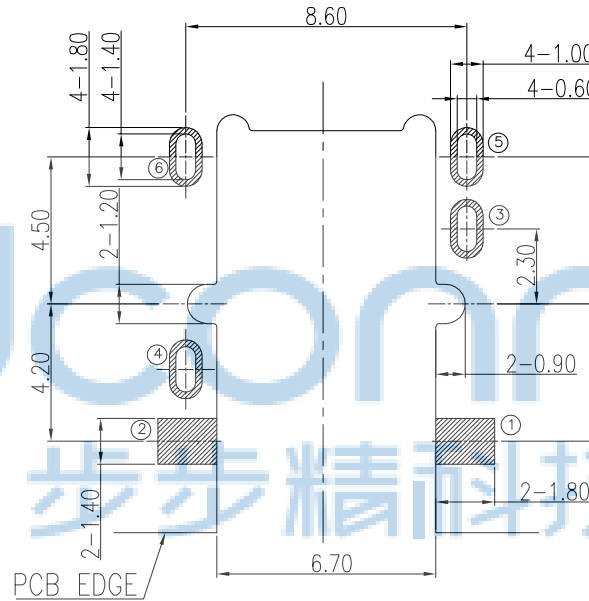

- NOTES:
- REQUEST OF THE SPECIFICATION:
    - CONTACT CURRENT RATING: 1A;
    - CONTACT RESISTANCE: 100 mΩ MAX.;
    - INSULATION RESISTANCE: 100MΩ MIN.;
    - DIELECTRIC WITHSTANDING: 500V AC MIN.;
    - DURABILITY: 5,000 CYCLES MIN.;
    - CONNECTOR MATING FORCES: 30N MAX.;
    - CONNECTOR UNMATING FORCES: 3N MIN.;

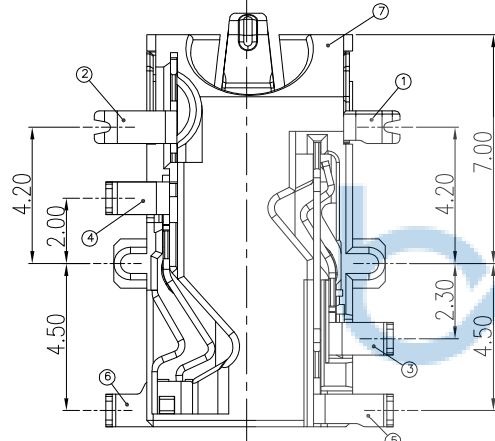
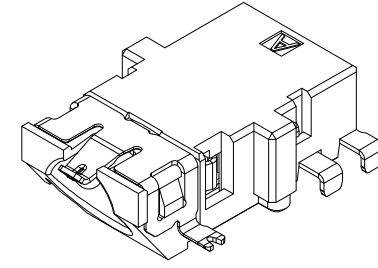
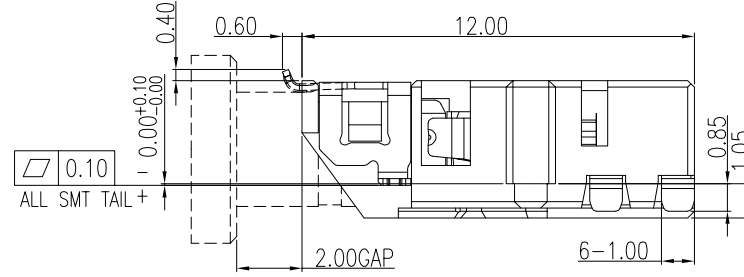
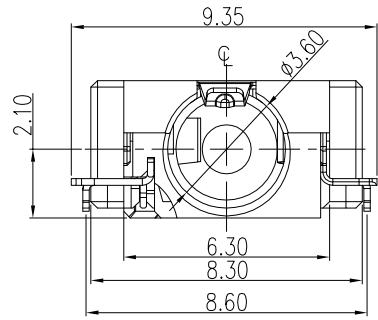
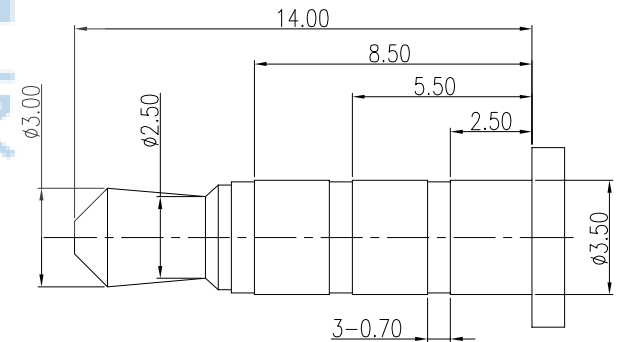

(ø3.50mm 4 POLE PLUG DETAIL DRAWING)

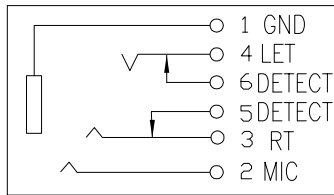
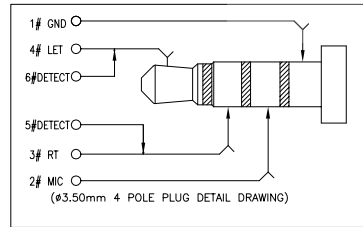

SCHEMATIC

RECOMMENDED PCB LAYOUT(TOP VIEW)  
(GENERAL TOLERANCE:±0.05)



ITEM	NAME	QTY	DESCRIPTION	NOTE
7	TERMINAL 6#	1	PHOSPHOR BRONZE; NICKEL UNDER PLATING OVERALL,GOLD FLASH ON SOLDER AREA	T=0.20
6	TERMINAL 5#	1	PHOSPHOR BRONZE; NICKEL UNDER PLATING OVERALL,GOLD FLASH ON SOLDER AREA	T=0.20
5	TERMINAL 4#	1	PHOSPHOR BRONZE; NICKEL UNDER PLATING OVERALL,GOLD FLASH ON SOLDER AREA ;GOLD FLASH ON CONTACT AREA	T=0.20
4	TERMINAL 3#	1	PHOSPHOR BRONZE; NICKEL UNDER PLATING OVERALL,GOLD FLASH ON SOLDER AREA ;GOLD FLASH ON CONTACT AREA	T=0.20
3	TERMINAL 2#	1	PHOSPHOR BRONZE; NICKEL UNDER PLATING OVERALL,GOLD FLASH ON SOLDER AREA ;GOLD FLASH ON CONTACT AREA	T=0.20
2	TERMINAL 1#	1	PHOSPHOR BRONZE; NICKEL UNDER PLATING OVERALL,GOLD FLASH ON SOLDER AREA ;GOLD FLASH ON CONTACT AREA	T=0.20
1	HOUSING	1	HIGHT TEMPERATURE PLASTIC COLOR BLACK	

THIS DOCUMENT IS THE SOLE PROPERTY OF BBJconn Technology Co.,Ltd. Corporation AND SHOULD NOT BE USED IN WHOLE OR IN PART WITHOUT PRIOR WRITTEN PERMISSION.		<b>深圳市步步精科技有限公司</b> NAME: 3.5耳机座 无头 沉板1.0 斜口 四脚插两脚贴 四节 (PJ35A083-F06J1BR-B) APPD. JM_Zheng 23/05/02 CHKD. LYX 23/05/02 DR. SGF 23/05/02 PDWG.NO: 0076-1	
.X: ±0.38 .XX: ±0.25 .XXX: ±0.13		X': ±3' X'': ±2' .XX': ±1'	
PJ. NO.: PJ.03.22-01-3012 SIZE: A4   DRW NO.: FINISH: SEE NOTES   MAT'L.: SEE NOTES SCALE: N/A   REV.: A0   UNIT: mm   PAGE: 1/1			

REV.	ECN NO.	CONTENT	DATE	ENGINEER
A0			2023 20/04	

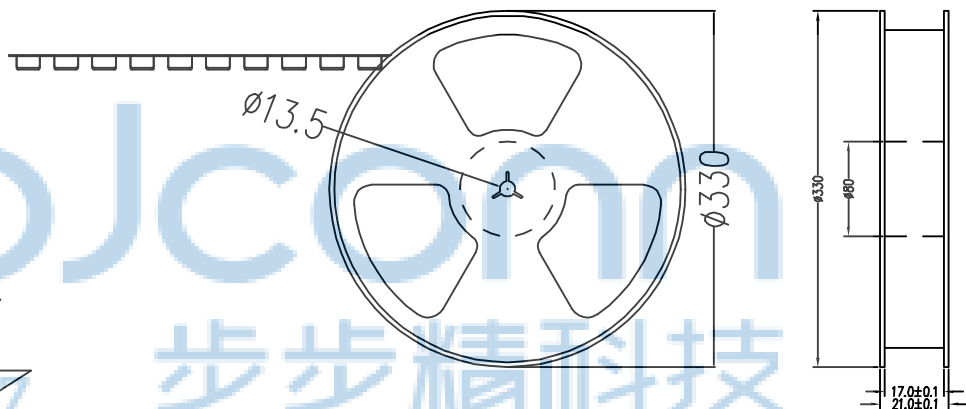
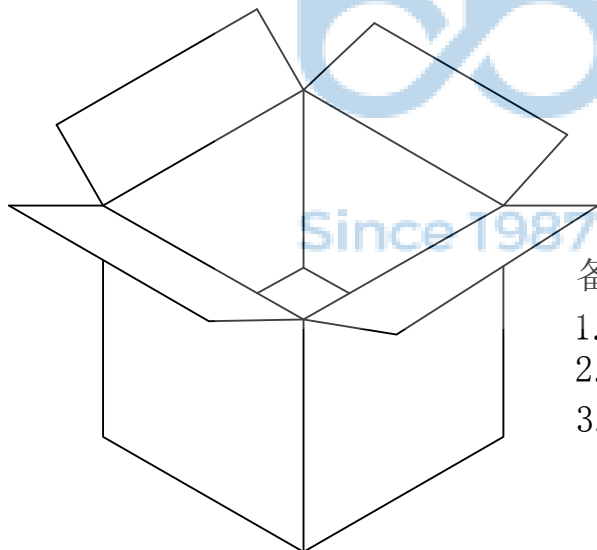
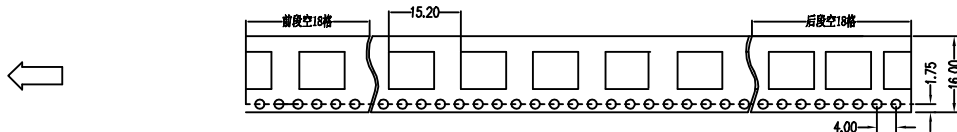
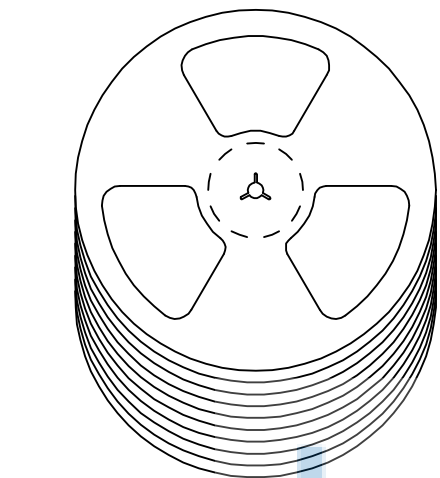

备注:

1. 包装数量: 1000/PCS/卷, 10卷/箱或15卷/箱。
2. 包装袋长度: 每卷前后各空10-20个空格, 中间包装。
3. 材质:  
载体: 聚丙烯 (PS), 阻抗 $10^{6-9} \Omega$   
上带: 聚乙烯 (PET), 阻抗 $10^{6-11} \Omega$   
卷盘: 聚苯乙烯。

纸箱规格: 345\*345\*23MM

纸箱规格: 345\*345\*35MM

THIS DOCUMENT IS THE SOLE PROPERTY OF BBJconn Technology Co.,Ltd. Corporation AND SHOULD NOT BE USED IN WHOLE OR IN PART WITHOUT PRIOR WRITTEN PERMISSION.		深圳市步步精科技有限公司 .X: ±0.38    .X': ±3" .XX: ±0.25    .X": ±2" .XXX: ±0.13    .XX': ±1"		NAME: 3.5耳机座 无头 沉板1.0 斜口 四脚插两脚贴 四节 (PJ35A083-F06J1BR-B)	
APPD.	JM_Zheng	23/05'02	PJ. NO.: PJ.03.22-01-3012 SIZE: A4   DRW NO.:		
CHKD.	LYX	23/05'02	FINISH: SEE NOTES		MAT'L.: SEE NOTES
PDWG.NO:	0076-1	DR.	SGF	23/05'02	SCALE: N/A   REV.: A0   UNIT: mm   PAGE: 1/1