

REV.	ECN NO.	CONTENT	DATE	ENGINEER
A0			2023 20/04	

- CONTACT CURRENT RATING: 1A.
- CONTACT RESISTANCE: 50 mΩ MAX.;
- INSULATION RESISTANCE: 1000Ω MIN.;
- DIELECTRIC WITHSTANDING: 500V AC MIN.;
- DURABILITY: 5,000 CYCLES MIN.;
- CONNECTOR MATING FORCES: 30N MAX.;
- CONNECTOR UNMATING FORCES: 3N MIN.;

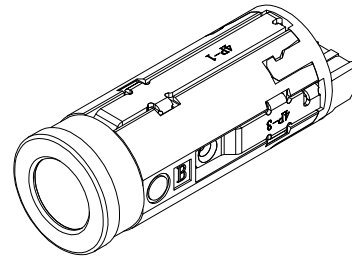

3D VIEW

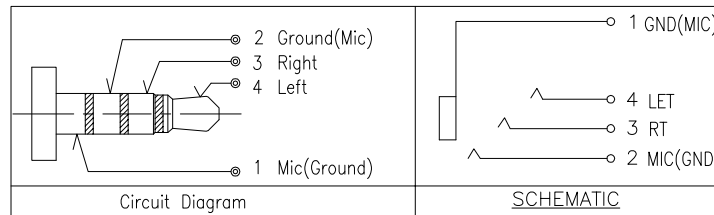
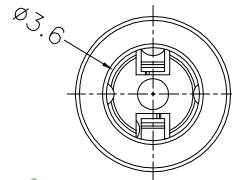
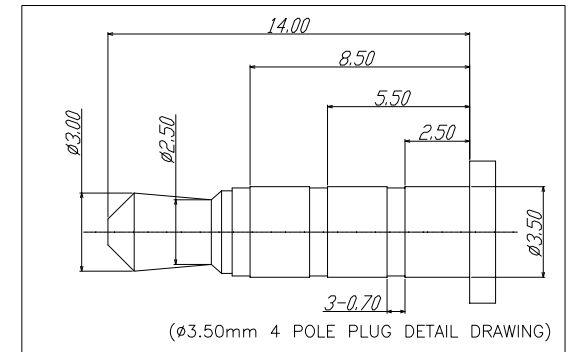
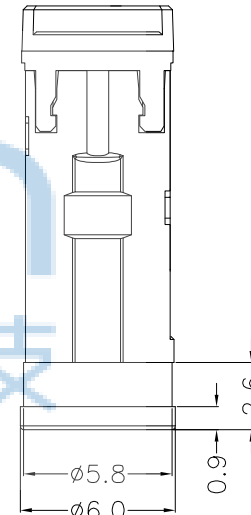
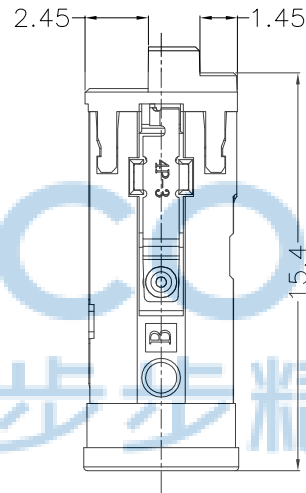
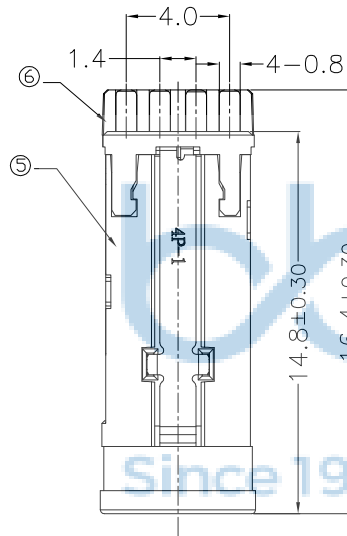
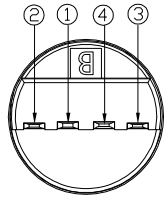

ITEM	NAME	QTY	DESCRIPTION	NOTE
7	COVER	1	ENGINEERING PLASTIC;COLOR WHITE	
6	HOUSING	1	ENGINEERING PLASTIC;COLOR WHITE	
5	TERMINAL 5#	1	STAINLESS STEEL; NICKEL UNDER PLATING OVERALL;GOLD PLATING ON CONTACT AREA	T=0.20mm
4	TERMINAL 4#	1	STAINLESS STEEL; NICKEL UNDER PLATING OVERALL;TIN PLATING ON SOLDER AREA ;GOLD PLATING ON CONTACT AREA	T=0.20mm
3	TERMINAL 3#	1	COPPER ALLOY; NICKEL UNDER PLATING OVERALL;TIN PLATING ON SOLDER AREA ;GOLD PLATING ON CONTACT AREA	T=0.20mm
2	TERMINAL 2#	1	COPPER ALLOY; NICKEL UNDER PLATING OVERALL;TIN PLATING ON SOLDER AREA ;GOLD PLATING ON CONTACT AREA	T=0.20mm
1	TERMINAL 1#	1	COPPER ALLOY; NICKEL UNDER PLATING OVERALL;TIN PLATING ON SOLDER AREA ;GOLD PLATING ON CONTACT AREA	T=0.20mm

THIS DOCUMENT IS THE SOLE PROPERTY OF BBJconn Technology Co.,Ltd. Corporation AND SHOULD NOT BE USED IN WHOLE OR IN PART WITHOUT PRIOR WRITTEN PERMISSION.

**深圳市步步精科技有限公司**

.X: ±0.38 X': ±3'  
.XX: ±0.25 X'': ±2'  
.XXX: ±0.13 .XX': ±1'

NAME: 3.5圆形耳机座 4PIN 四节 (PJ35A092-F04S1BP-A)

APPD. JM\_Zheng 23/05/02

PJ. NO.: PJ.05.21-01-3001  
SIZE: A4 DRW NO.:

CHKD. LYX 23/05/02

FINISH: SEE NOTES MAT'L.: SEE NOTES  
SCALE: N/A REV.: A0 UNIT: mm PAGE: 1/1

PDWG.NO: 0076-1

DR. SGF 23/05/02

REV.	ECN NO.	CONTENT	DATE	ENGINEER
A0			2023 20/04	

PE袋规格: 260\*185

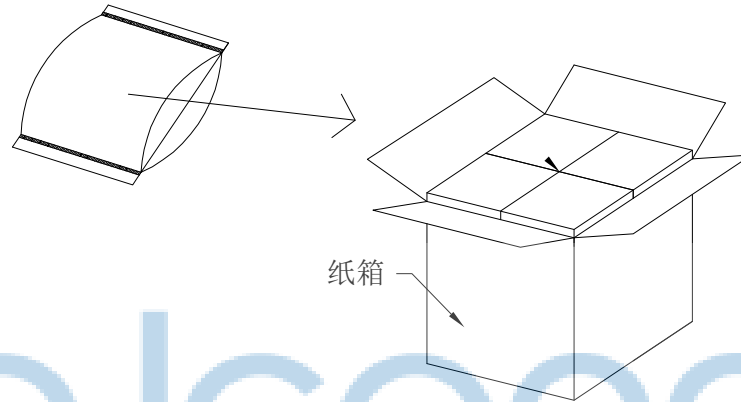

成品标签

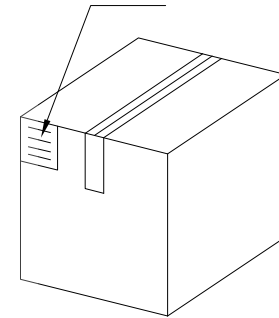

1. 包装要求:

- 1.1 每个PE袋包装1000pcs;
- 1.2 每1袋放一小纸盒;
- 1.3 每20个小纸盒放一个纸箱, 共计20000pcs;
- 1.4 纸箱外贴上标签

THIS DOCUMENT IS THE SOLE PROPERTY OF BBJconn Technology Co.,Ltd. Corporation AND SHOULD NOT BE USED IN WHOLE OR IN PART WITHOUT PRIOR WRITTEN PERMISSION.		 <b>深圳市步步精科技有限公司</b>	
PDWG.NO: 0076-1		.X: ±0.38    .X': ±3" .XX: ±0.25    .X'': ±2" .XXX: ±0.13    .XX': ±1"	
APPD.	JM_Zheng    23/05'02	NAME: 3.5圆形耳机座 4PIN 四节 (PJ35A092-F04S1BP-A)	
CHKD.	LYX    23/05'02	PJ. NO.: PJ.05.21-01-3001	
DR.	SGF    23/05'02	SIZE: A4    DRW NO.:	
		FINISH: SEE NOTES    MAT'L.: SEE NOTES	
		SCALE: N/A    REV.: A0    UNIT: mm    PAGE: 1/1	