

REV.	ECN NO.	CONTENT	DATE	ENGINEER
AO			2023 20/04	



NOTE:

- ELECTRICAL CHARACTERISTICS
  - VOLTAGE RATING:30V AC
  - CURRENT RATING:2.0A
  - CONTACT RESISTANCE: 50 milliohms MAX.
  - INSULATION RESISTANCE: 100 Megohms MIN.
  - DIELECTRIC WITHSTANDING VOLTAGE: 500V AC FOR 1 MINUTE.
- MECHANICAL CHARACTERISTICS
  - MATING&UNMATING FORCE: 1.0kgf~2.0kgf
  - DURIBILITY:10000CYCLES
- SALT SPRAY: 24H
- OPERATING TEMPERATURE:-40°C~85°C
- RoHS 2002/95/EC COMPLIANT.
- CRITICAL DIMENSIONS : ▽

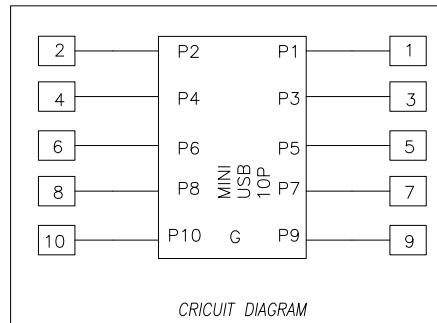
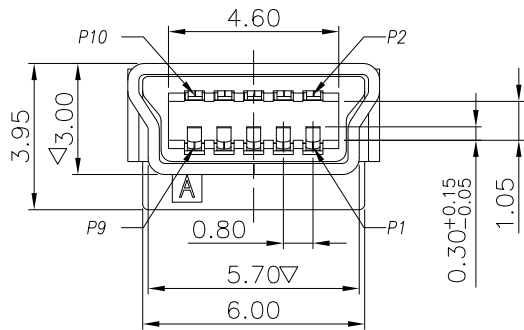
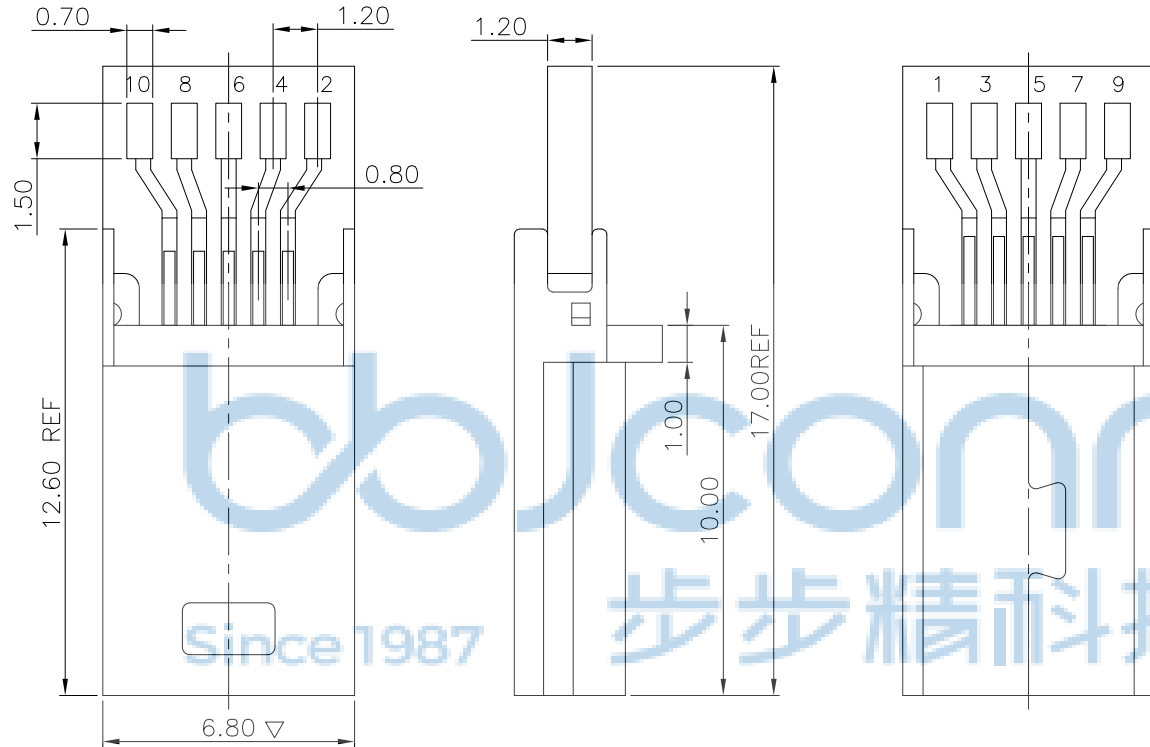

TABLE:

ITEM	SHELL NOTE	SALT SPRAY
1	SPCC, NI PLATE	24H
2	SPCC, Au PLATE	24H
3	BRASS, NI PLATE	48H

D	PCB	1	FR4-1	T-035
C	SHELL	1	SEE TABLE, 0.30t	SEE TABLE
B	CONTACT	10	C5191 0.20t	Gold Flash On Contact Area Tin plated on Solder tail All over Nickel Plated .
A	HOUSING	1	LCP	BLACK
NO	DFSCRIPTION	QTY	MATFRIAL	PLATING & COLOR

THIS DOCUMENT IS THE SOLE PROPERTY OF BBJconn Technology Co.,Ltd. Corporation AND SHOULD NOT BE USED IN WHOLE OR IN PART WITHOUT PRIOR WRITTEN PERMISSION.

PDWG.NO: 0366-2

**深圳市步步精科技有限公司**

NAME: MINI USB 10P公头焊线式 H=12.60 带PCB板 LCP黑胶 平口 铁壳

APPD. JM\_Zheng 23/05'02

CHKD. LYX 23/05'02

DR. SGF 23/05'02

PJ. NO.: UB.07.72-11-W001

SIZE: A4 DRW NO.:

FINISH: SEE NOTES MAT'L.: SEE NOTES

SCALE: N/A REV.: A3 UNIT: mm PAGE: 1/1

REV.	ECN NO	CONTENT	DATE	ENGINEER
A0			2023 20/04	

PE袋规格:\*\*\*X\*\*\* (以实际出货为准)

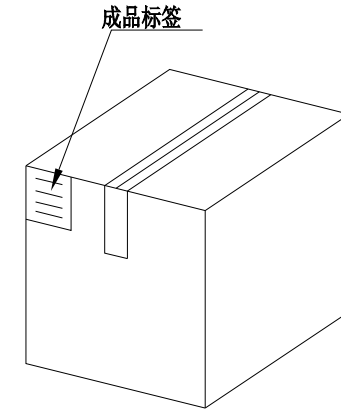
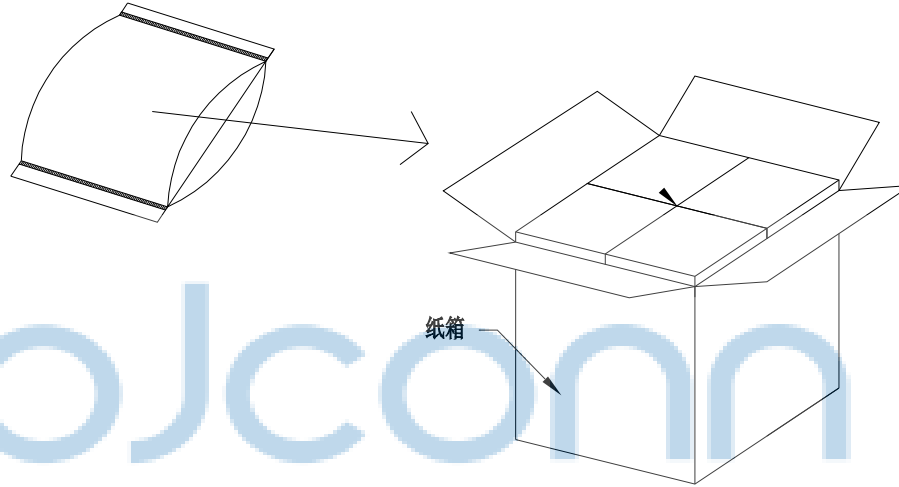

1. 包装要求:

- 1.1 每PE袋包装1000PCS;
- 1.2 每1袋放一小纸盒;
- 1.3 每20个小纸盒放一个纸箱, 共计20000PCS
- 1.4 纸箱外贴上标签



THIS DOCUMENT IS THE SOLE PROPERTY OF BBJconn Technology Co.,Ltd. Corporation AND SHOULD NOT BE USED IN WHOLE OR IN PART WITHOUT PRIOR WRITTEN PERMISSION.		<b>深圳市步步精科技有限公司</b>	
.X: ±0.38	X*: ±3*	NAME: MINI USB 10P公头焊线式 H=12.60 带PCB板 LCP黑胶 平口 铁壳	
.XX: ±0.25	.X*: ±2*	APPD. JM_Zheng 23/05'02	PJ. NO.: UB.07.72-11-W001
.XXX: ±0.13	.XX*: ±1*	CHKD. LYX 23/05'02	SIZE: A4 DRW NO.:
PDWG.NO: 0366-2	DR. SGF 23/05'02	FINISH: SEE NOTES	MAT'L.: SEE NOTES
		SCALE: N/A	REV.: A3 UNIT: mm PAGE: 1/1