

P.C.B Layout

产品规格说明: (specifications)

电器特性: (Electrical characteristics)

1. 接触阻抗: (Contact Resistance)

最大值30毫欧: (30 milliohms MAX)

2. 耐电压: (Dielectric Withstanding Voltage:)

500 伏特交流电 (500V AC AT Sea Level)

3. 绝缘阻抗: (Insulation Resistance:)

最小值1000兆欧姆 (1000 mega-ohms MIN)

机械性能: (Mechanical:)

1. 插入力: (Insertion Force)

最大3.57kg (3.57kg MAX)

2. 拔出力: (Unmating Force:)

最少1.02kg (1.02 kg MIN)

材料: Material:

1. 塑胶: (Housing) : PBT黑色防火 / 白色

2. 端子: (Contact): C2680

3. 外壳: (Shell): SPCC

电镀: (Finish):

1. 端子(Contact): Au Plated ON Contact Area Over 50~80u Ni, Sn Plated On Solder Tails. 接触点镀金, 脚镀锡。

接触点镀金 1u' 脚镀锡。

2. 外壳: (Shell): Nickel Plating 镀亮镍80u''

注明: 1. 标示 '^'为IPQC重点检测尺寸.

2. 所有物料均须符合RoHS标准.



TOLERANCE UNSPECIFIED		深圳市步步精科技有限公司		
.X±0.20 X° ±2°				
.XX±0.10 .X° ±1°		TITLE: USB 2.0AF 180度H=17.5 直插平口铁壳PBT白胶		
DRAWN/ DATE	设计 HMY	SIZE: A4	UNIT: MM.	PART. NO: UB.01.12-21-V004
CHECKED/ DATE	审核 LYX	SCALE: 1:1	PROJECTION	REV.: 版本
APPROVED/ DATE	核准 LJP	DWG. PATH	0383-1	SHEET: 页码

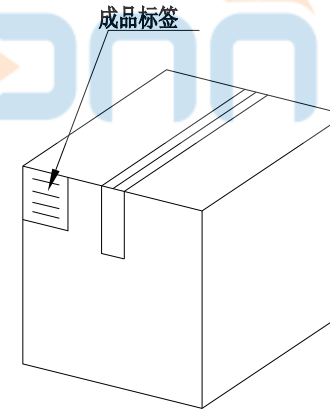
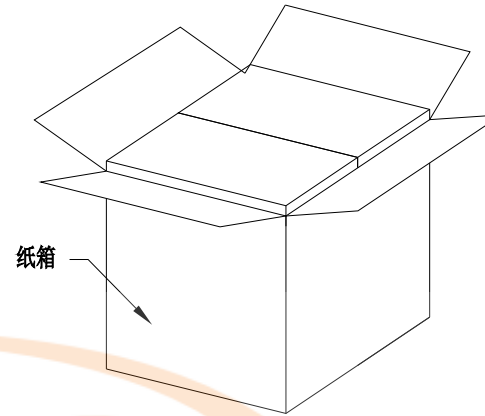
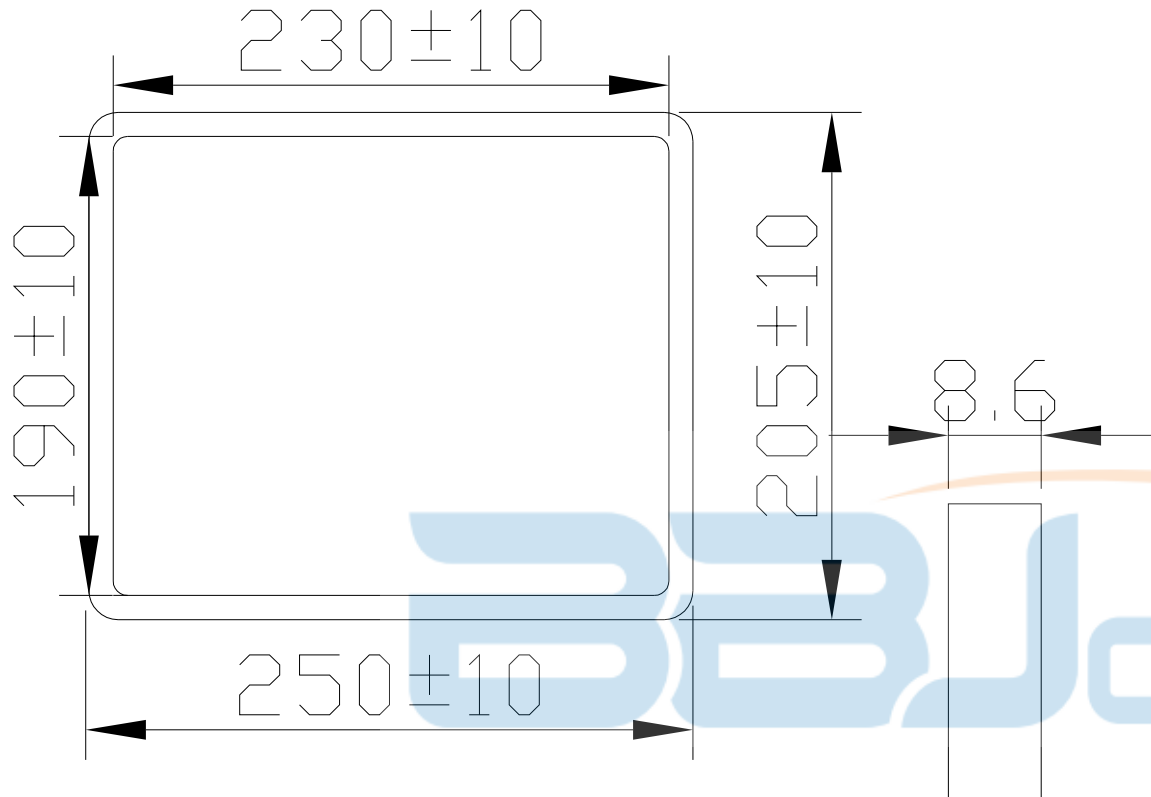

纸箱规格：350\*210\*290

1. 包装要求:

- 1.1 每盒吸塑盒包装100pcs;
- 1.2 每20盘放一箱，共计2000PCS;
- 1.3 纸箱外贴上标签



TOLERANCE UNSPECIFIED		深圳市步步精科技有限公司 TITLE: USB 2.0AF 180度H=17.5 直插平口铁壳PBT白胶			
.0	±0.35	SIZE: A4	UNIT: MM.	PART. NO: UB.01.12-21-V004	
.00	±0.25	CHECKED/ DATE	SCALE: 1:1	PROJECTION	REV.: 版本
.000	±0.15	APPROVED/ DATE	DWG. PATH	0383-1	SHEET: 页码
X. °	±2.00°				
CUSTOMER DRAWING					