



REV.	DESCRIPTION	NAME	DATE
A	NEWS ISSUE		

特性: Specifications:

电气: Electrical:

1. 接触阻抗: Contact Resistance: 30 milliohms MAX
2. 耐电压: Dielectric With Standing Voltage: 500 V AC AT Sea Level
3. 绝缘阻抗: Insulation Resistance: 1000 MEGA ohms MIN

机构: Mechanical:

1. 结合力: Mating Force: 35 N MAX 最大 35 N
2. 拔出力: Unmating Force: 8 N MIN 最少 8 N

材料: Material:

1. 塑胶: lcp.
2. 端子: Contact: C2680
3. 外壳: Shell: SPCC/C2680

电镀: Finish:

1. 端子: Contact: Plated Gold in Mating Area: Tin/Lead On Solder Talls. 接触点镀金, 脚镀锡
2. 外壳: Shell: Nickel Plating . 镀镍

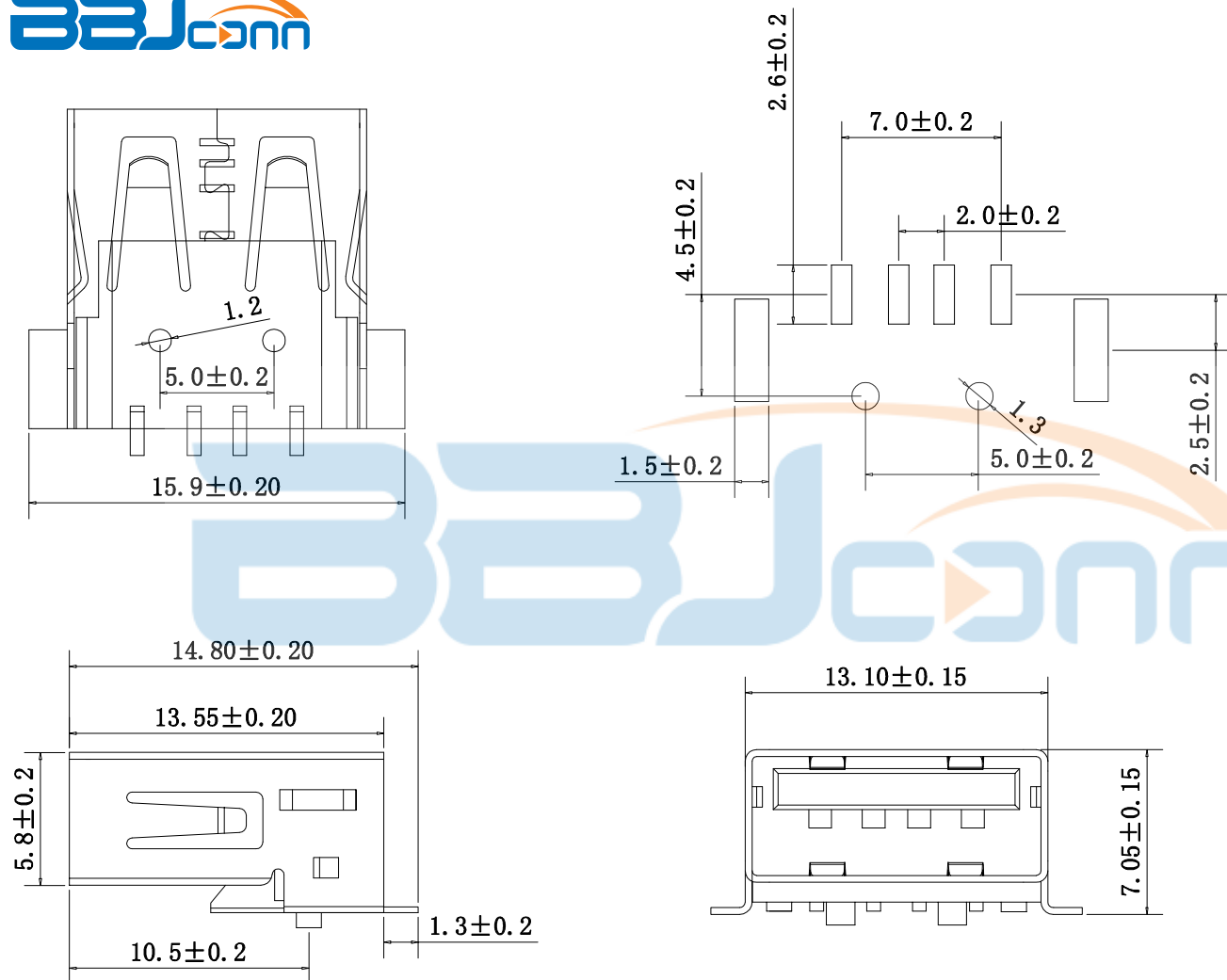

公差表 TOLERANCE UNLESS OTHERWISE			深圳市步步精科技有限公司			
X.	±0.30	X'	±6			
.X	±0.25	.X'	±3			
.XX	±0.20	.XX'	±2			
TITLE:			USB 2.0 AF 90度 L=13.6 俩脚全贴 带柱 平口 铁壳 LCP黑胶			
DRAWN/ DATE	设计	LHC	SIZE:A4	UNIT:MM.	PART. NO: UB.01.22-11-V004	
CHECKED/ DATE	审核	LYX	SCALE: 1:1		PROJECTION	REV.: 版本
APPROVED/ DATE	核准	LJP	DWG. PATH	0383-1		SHEET: 页码

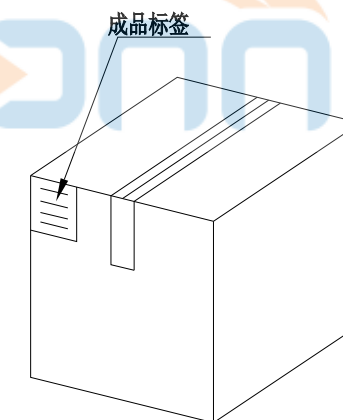
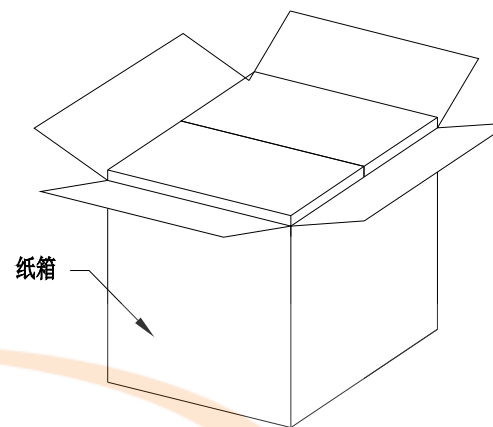
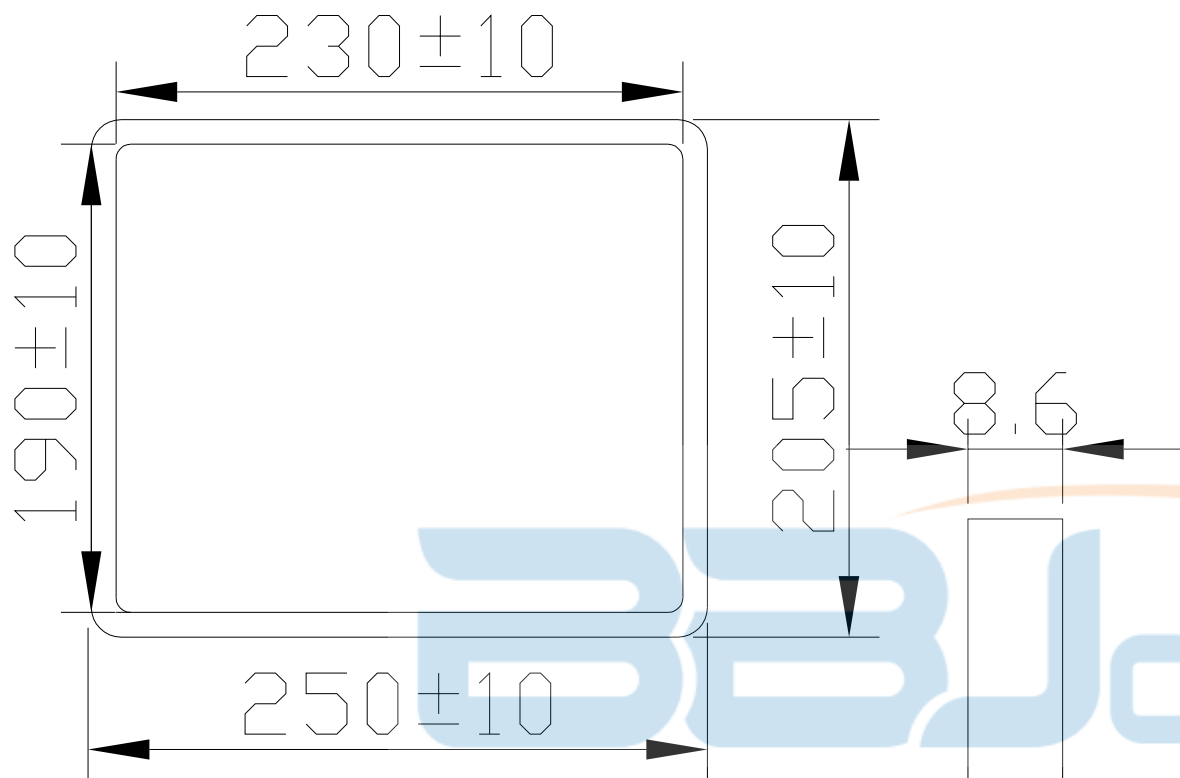

纸箱规格: 350*210*290

1. 包装要求:

- 1.1 每盒吸塑盒包装100pcs;
- 1.2 每20盘放一箱, 共计2000PCS;
- 1.3 纸箱外贴上标签



TOLERANCE UNSPECIFIED		深圳市步步精科技有限公司 TITLE: USB 2.0 AF 90度 L=13.6 俩脚全贴 带柱 平口 铁壳 LCP黑胶			
.0	±0.35	SIZE:A4	UNIT:MM.	PART. NO: UB.01.22-11-V004	
.00	±0.25	CHECKED/ DATE	SCALE: 1:1	PROJECTION	REV.: 版本
.000	±0.15	APPROVED/ DATE	DWG. PATH	0383-1	SHEET: 页码
X.°	±2.00°				
CUSTOMER DRAWING					