

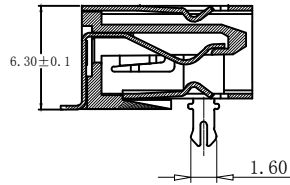

REV.	DESCRIPTION	NAME	DATE
A	NEWS ISSUE		

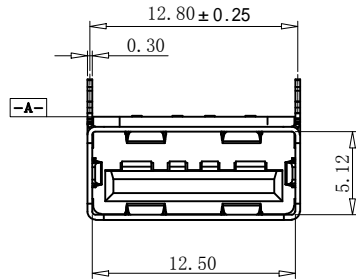

SECTION A-A

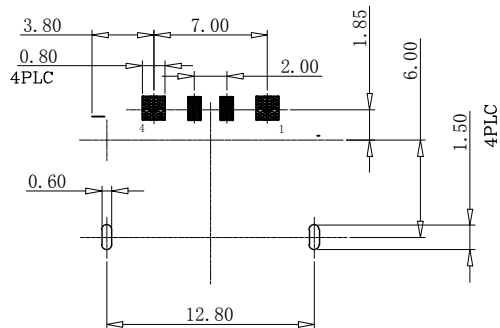
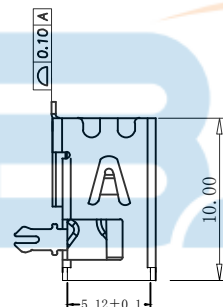
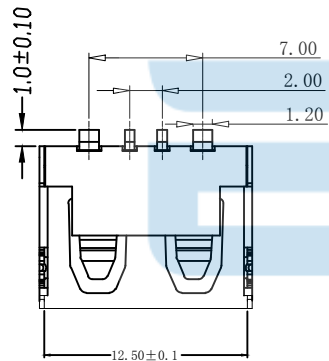

RECOMMENDED PCB LAYOUT
THICKNESS=1.0mm (TOLERANCES ±0.05)

规格说明:Specifications:

电气特性:Electrical:

1. 额定电流: Current Rating
5A/contact terminal
2. 额定电压: Voltage Rating
30V DC
3. 接触阻抗: Contact Resistance
30 milliohms MAX
4. 耐电压: Dielectric Withstanding Voltage:
500 V AC AT Sea Level
5. 绝缘阻抗: Insulation Resistance:
1000MEGA ohms MIN

物理性能:Mechanical:

1. 插拔力: Connector Mate and Unmate Force
Mate force: 3.57kgf (MAX)
Unmate force: 1.02kgf (MIN)
2. 端子保持力: Terminal Retention
1.2kgf (MIN)

原材料:Material:

1. 塑胶: Housing:
Hing Temperature Thermoplastics,
UL 94V-0 9T
2. 端子: Contact: Copper Alloy C2680
3. 外壳: Shell: Copper Alloy C2680/SPCC

电镀:Finish:

1. 端子: Contact: Plated Gold in Mating Area;
Tin On Solder Tails
2. 外壳: Shell:
Nickel Plating



TOLERANCE UNSPECIFIED	
X.X	±0.30
X.XX	±0.20
X.XXX	±0.10
X°	±5°
X.X°	±2°

深圳市步步精科技有限公司

TITLE: USB2.0 AF90度短体L=10.0 H=6.3 SMT前两脚插平口铜壳
4P大电流 端子脚长1.0MM镀金3u,5A PA9T黄胶 (114C)

DRAWN/ DATE	设计 LYX	SIZE:A4	UNIT:MM.	PART.NO: UB.01.12-82-V002	
CHECKED/ DATE	审核 HMY	SCALE: 1:1	PROJECTION		REV.: 版本
APPROVED/ DATE	核准 LJP	DWG. PATH	0383-1	SHEET: 页码	

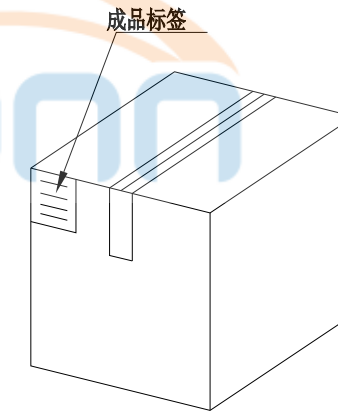
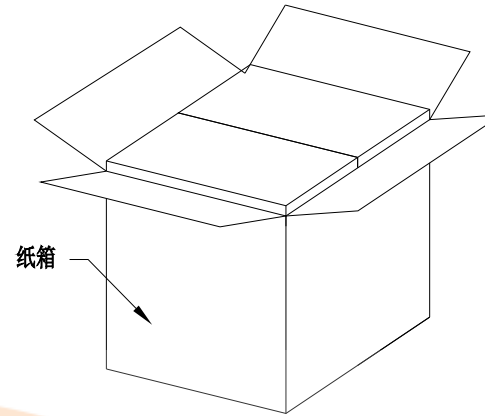
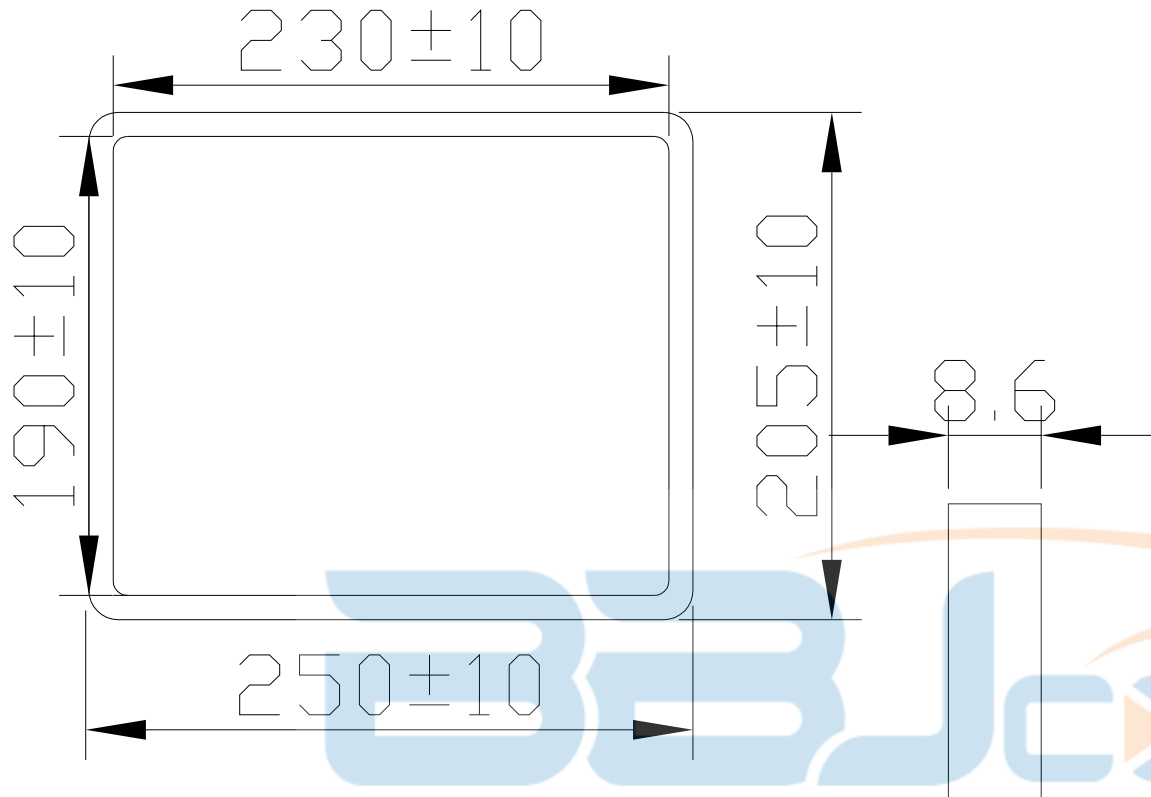

纸箱规格: 350*210*290

1. 包装要求:

- 1.1 每盒吸塑盒包装100pcs;
- 1.2 每20盘放一箱, 共计2000PCS;
- 1.3 纸箱外贴上标签



TOLERANCE UNSPECIFIED		深圳市步步精科技有限公司					
.0	±0.35					TITLE: USB2.0 AF90度短体L=10.0 H=6.3 SMT前两脚插平口铜壳 4P大电流 端子脚长1.0MM镀金3u, PA9T黄胶 (114C)	
.00	±0.25	DRAWN/	设计	LYX	SIZE: A4		
.000	±0.15	DATE					
X. °	±2.00°	CHECKED/	审核	HMY	SCALE: 1:1	PROJECTION	REV.: 版本
CUSTOMER DRAWING		DATE					
		APPROVED/	核准	LJP	DWG. PATH	0383-1	SHEET: 页码
		DATE					