

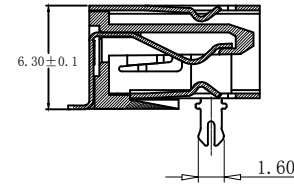

REV.	DESCRIPTION	NAME	DATE
A	NEWS ISSUE		

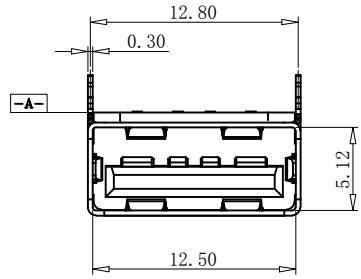

SECTION A-A

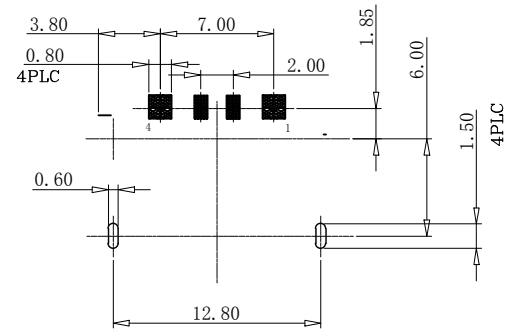
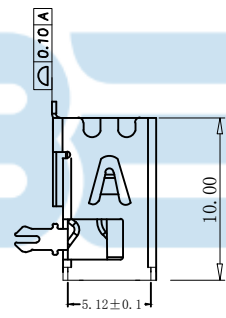
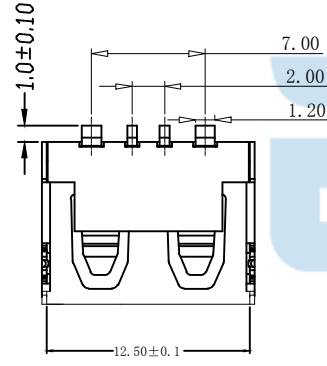

RECOMMENDED PCB LAYOUT  
THICKNESS=1.0mm (TOLERANCES ±0.05)



规格说明:Specifications:

电气特性:Electrical:

1. 额定电流: Current Rating  
5A/contact terminal
2. 额定电压: Voltage Rating  
30V DC
3. 接触阻抗: Contact Resistance  
30 milliohms MAX
4. 耐电压: Dielectric Withstanding Voltage:  
500 V AC AT Sea Level
5. 绝缘阻抗: Insulation Resistance:  
1000MEGA ohms MIN

物理性能: Mechanical:

1. 插拔力: Connector Mate and Unmate Force  
Mate force: 3.57kgf (MAX)  
Unmate force: 1.02kgf (MIN)
2. 端子保持力: Terminal Retention  
1.2kgf (MIN)

原材料: Material:

1. 塑胶: Housing:  
Hing Temperature Ternmaplastics,  
U1 94V-0 PA9T
2. 端子: Contact: Copper Alloy C2680
3. 外壳: Shell: Copper Alloy C2680/SPCC

电镀: Finish:

1. 端子: Contact: Plated Gold in Mating Area;  
Tin On Solder Talls
2. 外壳: Shell:  
Nickel Plating

TOLERANCE UNSPECIFIED	
X. X	±0.30
X. XX	±0.20
X. XXX	±0.10
X°	±5°
X. X°	±2°

**BBJconn Technology Co., Ltd.** 深圳市步步精科技有限公司

TITLE: USB2.0 AF90度短体L=10.0 H=6.3 SMT前两脚插平口铜壳  
4P大电流5A 端子脚长1.0MM镀金3U, PA9T橙胶 (1505C)

DRAWN/ DATE	设计 TSP	SIZE: A4	UNIT: MM.	PART. NO:	
CHECKED/ DATE	审核 LYX	SCALE: 1:1		PROJECTION	REV.: 版本
APPROVED/ DATE	核准 LJP	DWG. PATH	0383-1		SHEET: 页码

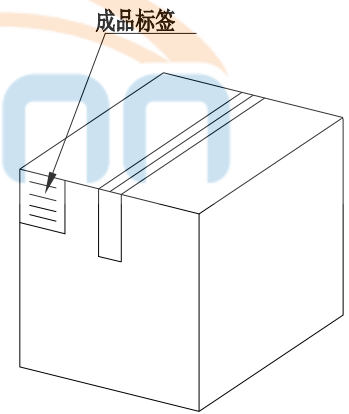
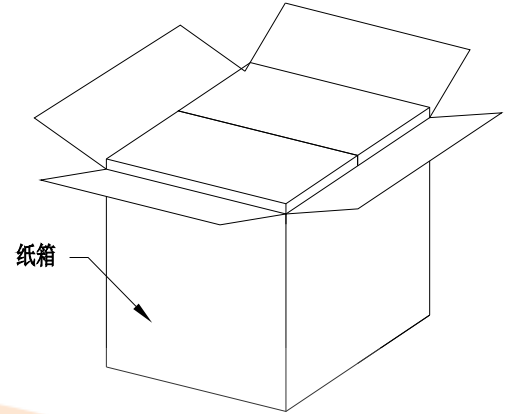
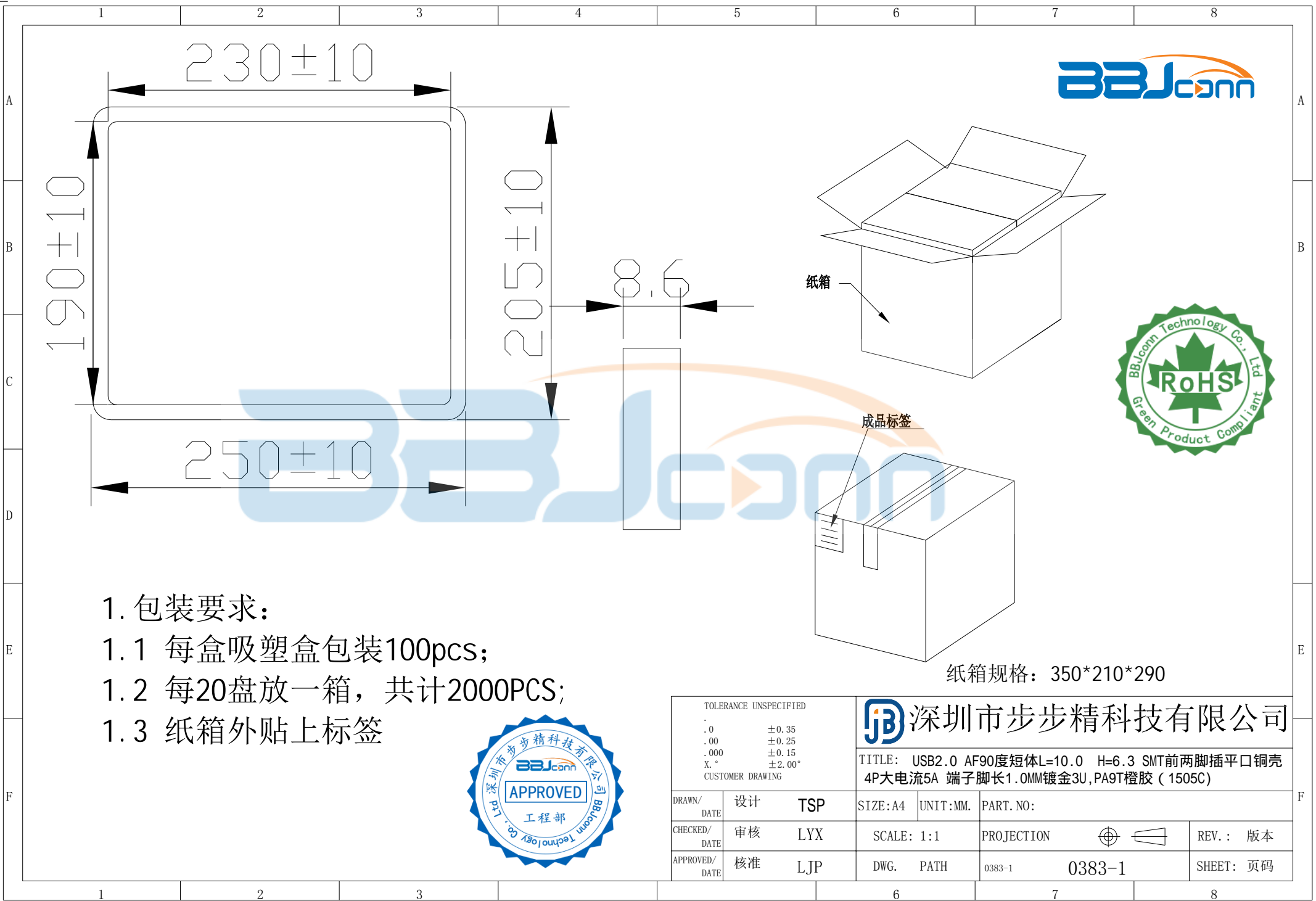

纸箱规格：350\*210\*290

1. 包装要求:

- 1.1 每盒吸塑盒包装100pcs;
- 1.2 每20盘放一箱，共计2000PCS;
- 1.3 纸箱外贴上标签



TOLERANCE UNSPECIFIED		深圳市步步精科技有限公司 TITLE: USB2.0 AF90度短体L=10.0 H=6.3 SMT前两脚插平口铜壳 4P大电流5A 端子脚长1.0MM镀金3U, PA9T橙胶 (1505C)			
.0	±0.35				
.00	±0.25				
.000	±0.15				
X. °	±2.00°				
CUSTOMER DRAWING					
DRAWN/ DATE	设计 TSP	SIZE: A4	UNIT: MM.	PART. NO:	
CHECKED/ DATE	审核 LYX	SCALE: 1:1	PROJECTION	REV.: 版本	
APPROVED/ DATE	核准 LJP	DWG. PATH	0383-1	0383-1	SHEET: 页码