

REV.	DESCRIPTION	NAME	DATE
A	NEWS ISSUE		

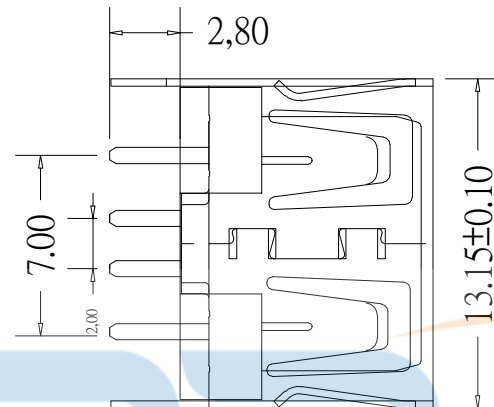
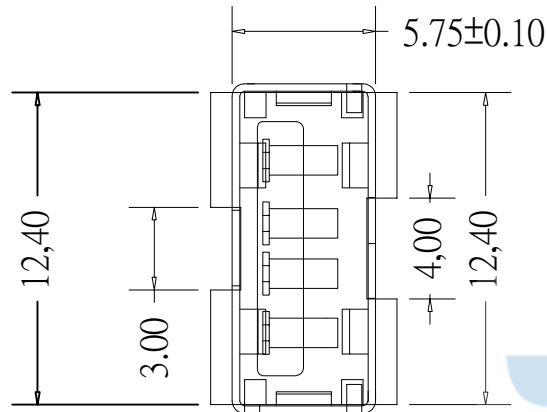

规格说明:Specifications:

电气特性:Electrical:

1. 额定电流: Current Rating
1.5A/contact terminal
2. 额定电压: Voltage Rating
30V DC
3. 接触阻抗: Contact Resistance
30 milliohms MAX
4. 耐电压: Dielectric Withstanding Voltage:
500 V AC AT Sea Level
5. 绝缘阻抗: Insulation Resistance:
1000MEGA ohms MIN

物理性能:Mechanical:

1. 插拔力: Connector Mate and Unmate Force
Mate force: 3.57kgf (MAX)
Unmate force: 1.02kgf (MIN)
2. 端子保持力: Terminal Retention
1.02kgf (MIN)

原材料:Material:

1. 塑胶: Housing: PA9t 1050C
Hing Temperature Tnermaplastics,
 2. 端子: Contact: Copper Alloy C2680
 3. 外壳: Shell: Copper Alloy C2680/SPCC
- 电镀: Finish:
1. 端子: Contact: Plated Gold in Mating Area;
Tin On Solder Talls
 2. 外壳: Shell:
铁壳四周镀80U" (MIN) 锡
Nickel Plating

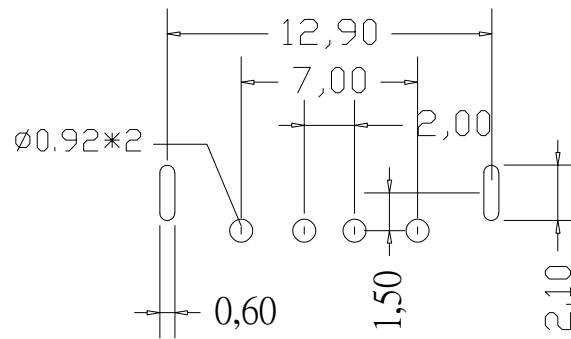
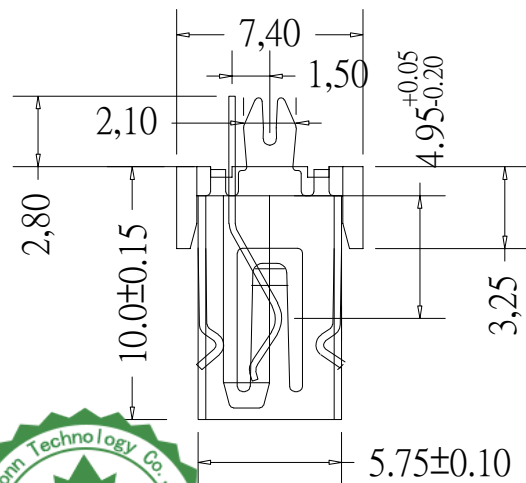

TOLERANCE UNSPECIFIED		深圳市步步精科技有限公司	
.0	±0.35	TITLE:	
.00	±0.25	USB 2.0 AF 180度 直插 (鱼叉脚) H=10.0 平口 PA9T (橙胶1505C) 铁壳	
.000	±0.15	DRAWN/ DATE	设计 HMY
X.°	±2.00°	CHECKED/ DATE	审核 LYX
CUSTOMER DRAWING		APPROVED/ DATE	核准 LJP
SIZE: A4	UNIT: MM.	PART. NO:	UB.01.12-51-V004
SCALE: 1:1	PROJECTION	REV.:	版本
DWG. PATH	0383-1	SHEET:	页码

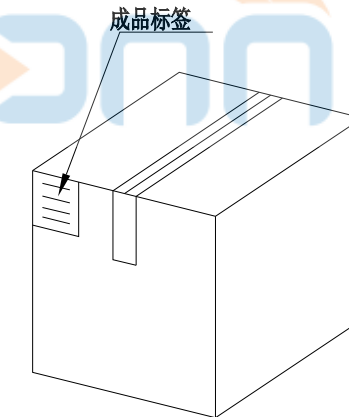
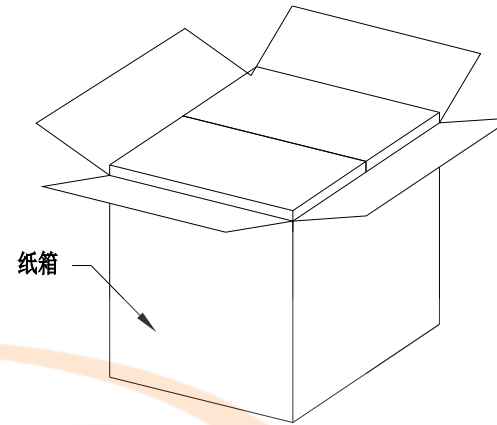
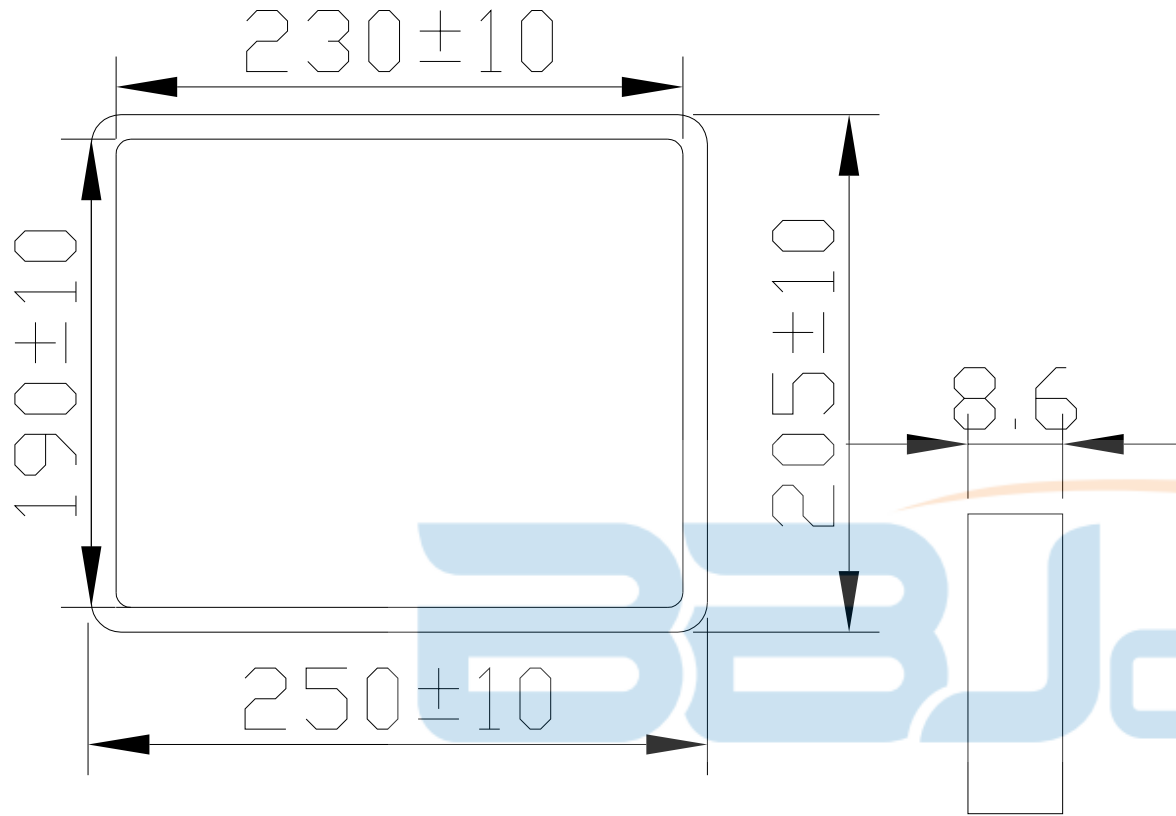

纸箱规格：350*210*290

1. 包装要求:

- 1.1 每盒吸塑盒包装100pcs;
- 1.2 每20盘放一箱，共计2000PCS;
- 1.3 纸箱外贴上标签



TOLERANCE UNSPECIFIED		深圳市步步精科技有限公司 TITLE: USB 2.0 AF 180度 直插(鱼叉脚) H=10.0 平口 PA9T(橙胶1505C) 铁壳			
.0	±0.35	SIZE:A4	UNIT:MM.	PART. NO: UB.01.12-51-V004	
.00	±0.25	CHECKED/ DATE	SCALE: 1:1	PROJECTION	REV.: 版本
.000	±0.15	APPROVED/ DATE	DWG. PATH	0383-1	SHEET: 页码
X.°	±2.00°				
CUSTOMER DRAWING					