

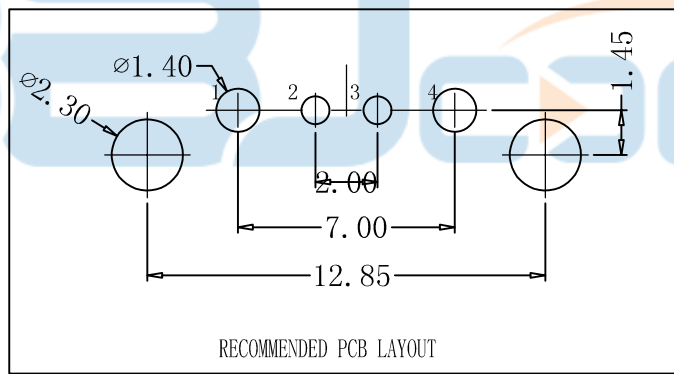

REV.	DESCRIPTION	NAME	DATE
A	NEWS ISSUE		

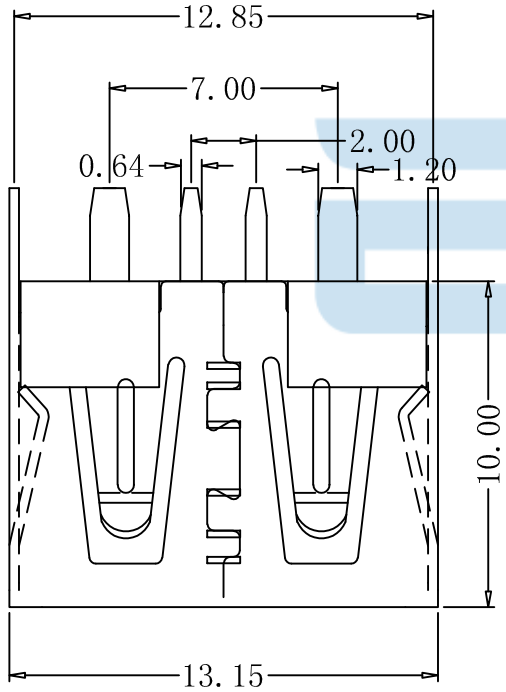
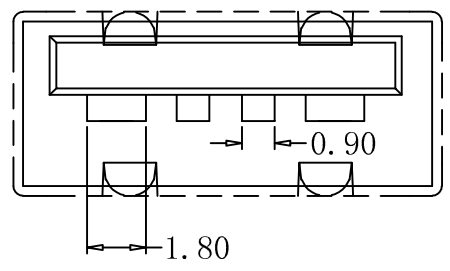
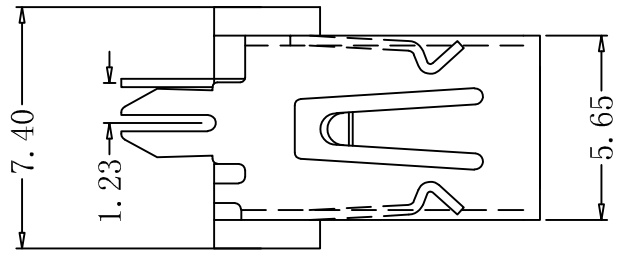

NOTE:

1. ELECTRICAL CHARACTERISTICS
    - 1-1. CONTACT RESISTANCE: 30 milliohms MAX.
    - 1-2. INSULATION RESISTANCE: 1,000 Megohms MIN.
    - 1-3. DIELECTRIC WITHSTANDING VOLTAGE: 500V AC MIN
    - 1-4. OPERATION TEMPERATURE:-20°C TO +85°C
  2. MECHANICAL CHARACTERISTICS
    - 2-1. RETENTION FORCE:MIN.100gf/PIN
    - 2-2. DURABILITY: 6,000 CYCLES
    - 2-3.INSERTION FORCE:3.57Kg MAXIMU AT A  
MAXIMUM RATE OF 12.5mm  
EXTRACTION FORCE:1.02Kg MIN AT A  
MAXIMUM RATE OF 12.5mm
  3. MATERIAL:
    - 3-1.HOUSING: PA9T UL 94-V0. COLOR: orange
    - 3-2. CONTACT:Phosphor copper 7025 terminalT=0.25±0.02mm  
(SURFACE PLATING:Gold 1U"+Sn60-100U"+Ni40U")
    - 3-3. SHEEL: C2680/SPCC
- RoHS Compliant



GENERAL TOLERANCES		深圳市步步精科技有限公司			
.X:	±0.20	TITLE:			
.XX:	±0.10	USB 2.0 180度 直脚直插 短体H=10.0 平口 PA9T橙胶 大电流 (5A) 铁壳			
.XXX:	±0.05	DRAWN/ DATE	设计 TSP	SIZE:A4	UNIT:MM.
NGEL:	± 3.0°	CHECKED/ DATE	审核 LYX	PART. NO:	UB.01.12-51-V003
		APPROVED/ DATE	核准 LJP	SCALE: 1:1	PROJECTION
					REV. : 版本
					SHEET: 页码
					0383-1

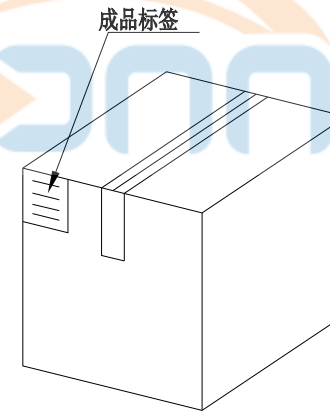
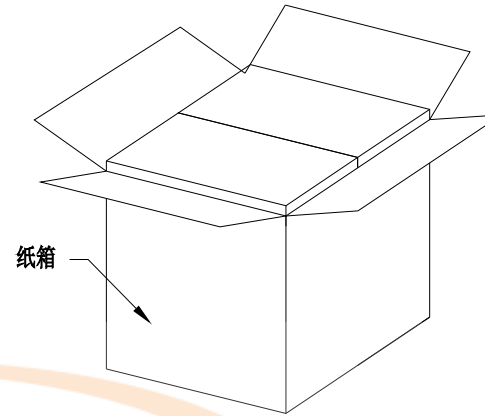
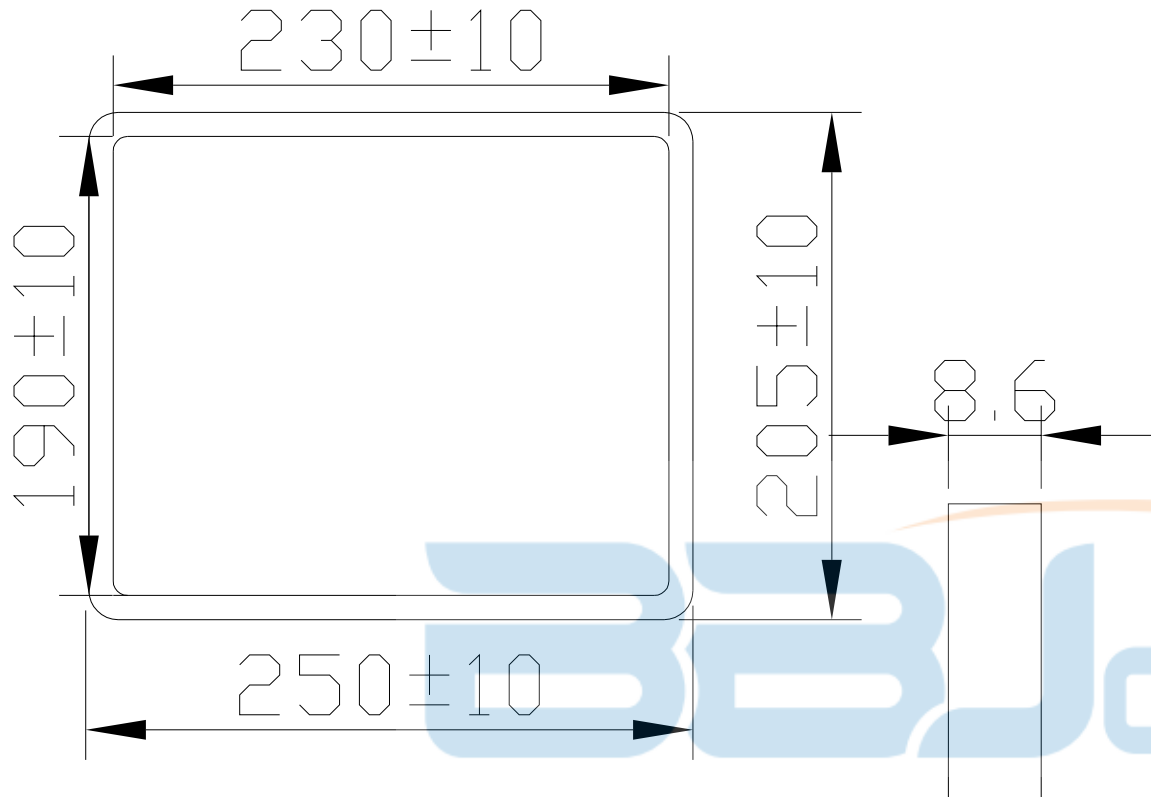

纸箱规格: 350\*210\*290

### 1. 包装要求:

- 1.1 每盒吸塑盒包装100 pcs;
- 1.2 每20盘放一箱, 共计2000PCS;
- 1.3 纸箱外贴上标签



TOLERANCE UNSPECIFIED		深圳市步步精科技有限公司 TITLE: USB 2.0 180度 直脚直插 短体H=10.0 平口 PA9T橙胶 大电流 (5A) 铁壳			
.0	±0.35	SIZE: A4	UNIT: MM.	PART. NO: UB.01.12-51-V003	
.00	±0.25	DRAWN/ DATE		设计	TSP
.000	±0.15	CHECKED/ DATE		审核	LYX
X.°	±2.00°	APPROVED/ DATE		核准	LJP
CUSTOMER DRAWING		DWG. PATH		0383-1	
		PROJECTION		REV.: 版本	
		SHEET: 页码			