

REV.	DESCRIPTION	NAME	DATE
A	NEWS ISSUE		



规格说明:Specifications:

电气特性:Electrical:

1. 额定电流: Current Rating
3A/contact terminal
2. 额定电压: Voltage Rating
30V DC
3. 接触阻抗: Contact Resistance
30 milliohms MAX
4. 耐电压: Dielectric Withstanding Voltage:
500 V AC AT Sea Level
5. 绝缘阻抗: Insulation Resistance:
1000MEGA ohms MIN

物理性能:Mechanical:

1. 插拔力: Connector Mate and Unmate Force
Mate force: 3.57kgf (MAX)
Unmate force: 1.02kgf (MIN)
2. 端子保持力: Terminal Retention
1.2kgf (MIN)

原材料:Material:

1. 塑胶: Housing:
Hing Temperature Ternmaplastics, PA9T
2. 端子: Contact:
Copper Alloy C2680
3. 外壳: Shell: SPCC

电镀:Finish:

1. 端子: Contact: Plated Gold in Mating Area;
Tin On Solder Talls
2. 外壳: Shell: Nickel Plating

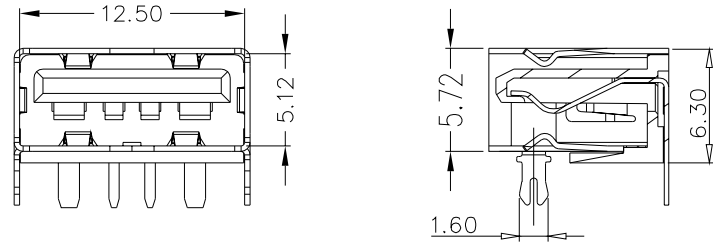

SECTION A-A

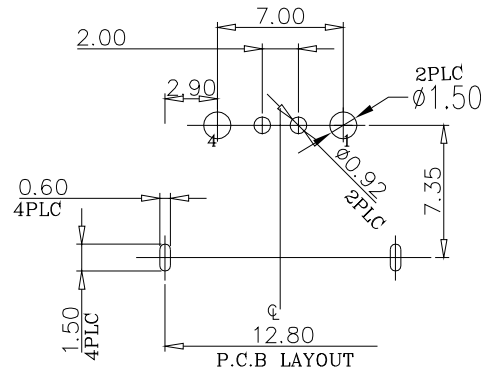
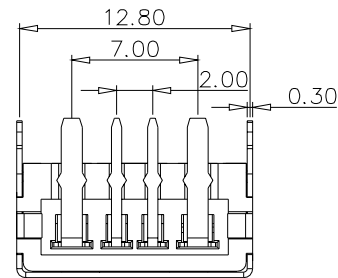
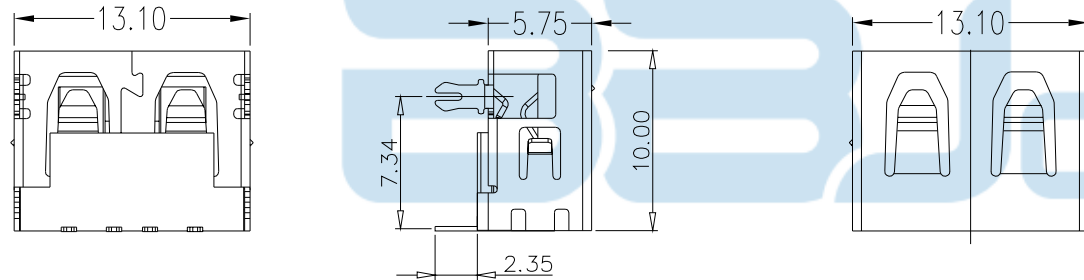

TOLERANCES .X ±0.30 .XX ±0.20 .XXX ±0.10 ANGLES ±2.00°		深圳市步步精科技有限公司			
		TITLE: USB AF 短体L=10.0前俩脚插90度H=6.3 PA9T橙胶 铁壳平口 大电流(过260度)			
DRAWN/ DATE 设计 HMY	SIZE: A4 UNIT: MM.	PART. NO.: UB.01.12-51-V002			
CHECKED/ DATE 审核 LYX	SCALE: 1:1	PROJECTION 	REV.: 版本		
APPROVED/ DATE 核准 LJP	DWG. PATH	0383-1		SHEET: 页码	

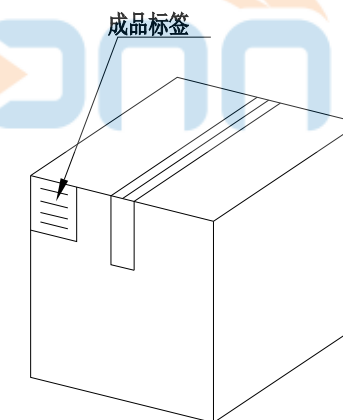
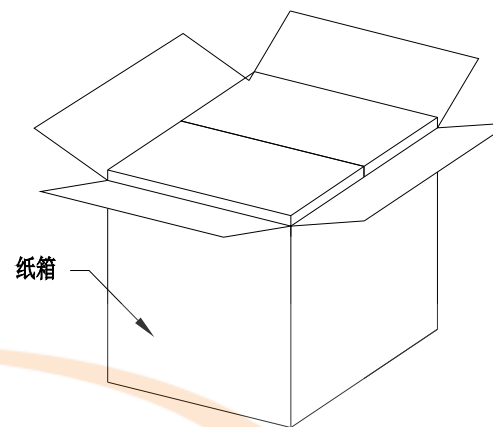
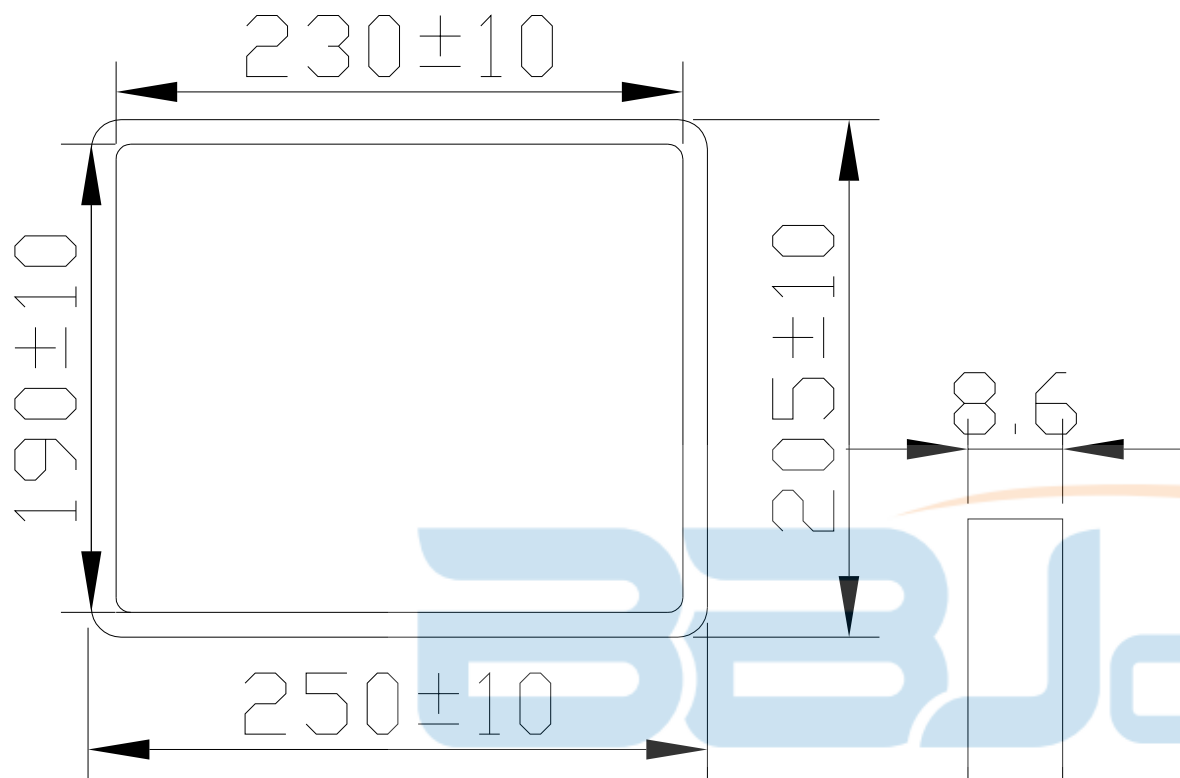

纸箱规格：350*210*290

1. 包装要求:

- 1.1 每盒吸塑盒包装100pcs;
- 1.2 每20盘放一箱，共计2000PCS;
- 1.3 纸箱外贴上标签



TOLERANCE UNSPECIFIED		深圳市步步精科技有限公司 TITLE: USB AF 短体L=10.0前俩脚插90度H=6.3 PA9T橙胶 铁壳平口 大电流(过260度)			
.0	±0.35	SIZE:A4	UNIT:MM.	PART. NO: UB.01.12-51-V002	
.00	±0.25	CHECKED/ DATE	SCALE: 1:1	PROJECTION	REV.: 版本
.000	±0.15	APPROVED/ DATE	DWG. PATH	0383-1	SHEET: 页码
X.°	±2.00°				
CUSTOMER DRAWING					