

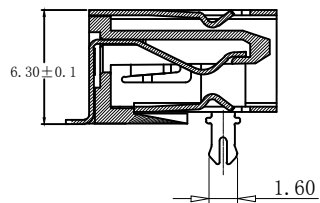

REV.	DESCRIPTION	NAME	DATE
A	NEWS ISSUE		

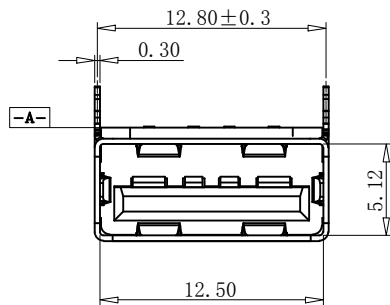

SECTION A-A

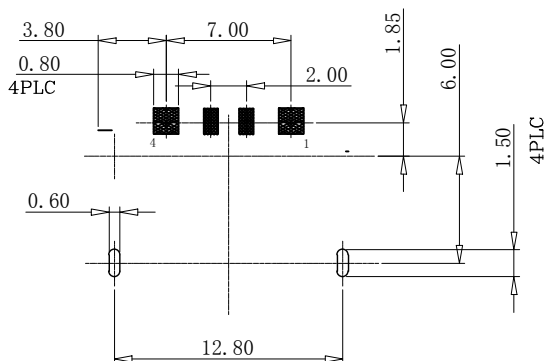
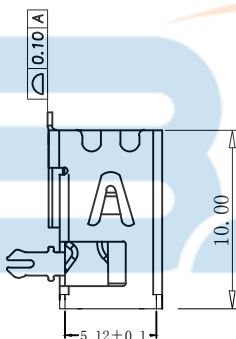
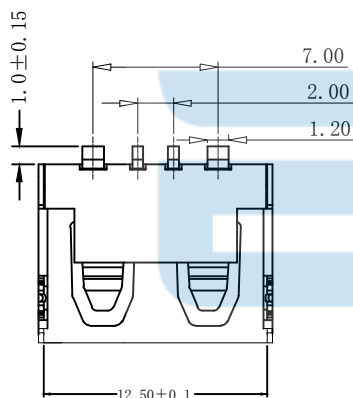

RECOMMENDED PCB LAYOUT
THICKNESS=1.0mm (TOLERANCES ±0.05)



规格说明:Specifications:

电气特性:Electrical:

1. 额定电流: Current Rating
5A/contact terminal
2. 额定电压: Voltage Rating
30V DC
3. 接触阻抗: Contact Resistance
30 milliohms MAX
4. 耐电压: Dielectric Withstanding Voltage:
500 V AC AT Sea Level
5. 绝缘阻抗: Insulation Resistance:
1000MEGA ohms MIN

物理性能: Mechanical:

1. 插拔力: Connector Mate and Unmate Force
Mate force: 3.57kgf (MAX)
Unmate force: 1.02kgf (MIN)
2. 端子保持力: Terminal Retention
1.2kgf (MIN)

原材料: Material:

1. 塑胶: Housing:
Hing Temperature Ternmaplastics,
UL 94V-0 9T
2. 端子: Contact: Copper Alloy C7025
3. 外壳: Shell: Copper Alloy C2680/SPCC

电镀: Finish:

1. 端子: Contact: Plated Gold in Mating Area;
Tin On Solder Talls
2. 外壳: Shell:
Nickel Plating

TOLERANCE UNSPECIFIED	
X.X	±0.30
X.XX	±0.20
X.XXX	±0.10
X°	±5°
X.X°	±2°

深圳市步步精科技有限公司

TITLE: USB2.0 AF90度短体L=10.0 H=6.3 SMT前两脚插 平口 铜壳
4P大电流(5A) 端子(C7025)脚长1.0MM镀金3u,蓝色PA9T (287C)

DRAWN/ DATE	设计 LYX	SIZE:A4	UNIT:MM.	PART. NO: UB.01.12-32-V001	
CHECKED/ DATE	审核 HMY	SCALE: 1:1	PROJECTION		REV.: 版本
APPROVED/ DATE	核准 LJP	DWG. PATH	0383-1	SHEET: 页码	

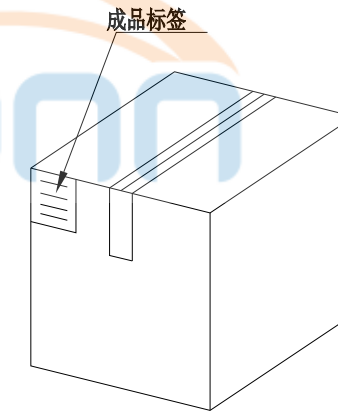
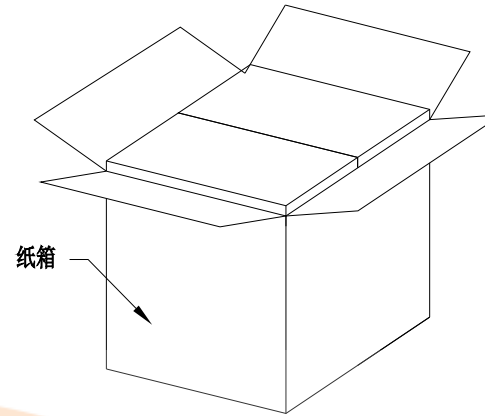
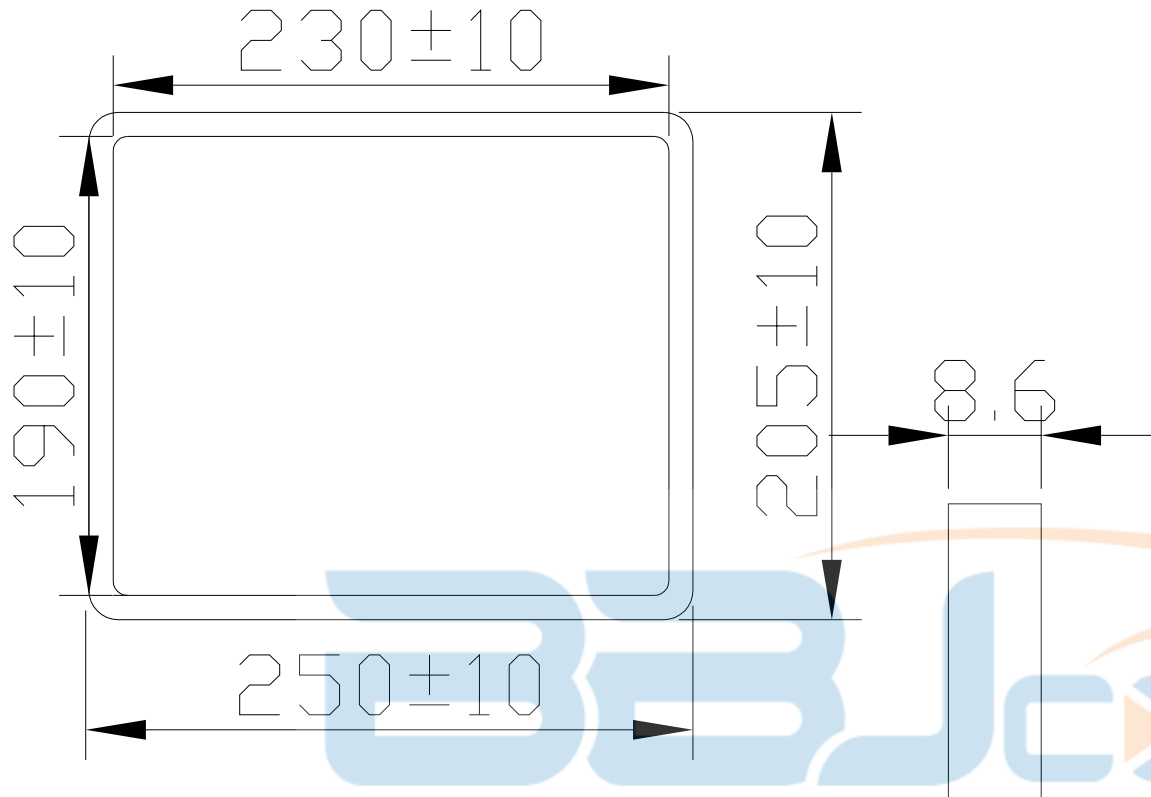

纸箱规格: 350*210*290

1. 包装要求:

- 1.1 每盒吸塑盒包装100pcs;
- 1.2 每20盘放一箱, 共计2000PCS;
- 1.3 纸箱外贴上标签



TOLERANCE UNSPECIFIED		深圳市步步精科技有限公司 TITLE: USB2.0 AF90度短体L=10.0 H=6.3 SMT前两脚插 平口 铜壳 4P大电流(5A) 端子(C7025)脚长1.0MM镀金3u, 蓝色PA9T (287C))								
.0	±0.35									
.00	±0.25	DRAWN/ DATE		设计	LYX	SIZE: A4	UNIT: MM.	PART. NO: UB.01.12-32-V001		
.000	±0.15	CHECKED/ DATE		审核	HMY	SCALE: 1:1		PROJECTION	REV.: 版本	
X. °	±2.00°	APPROVED/ DATE		核准	LJP	DWG. PATH	0383-1		SHEET: 页码	
CUSTOMER DRAWING										