

RECOMMENDED PCB LAYOUT
THICKNESS=1.0mm (TOLERANCES ±0.05)

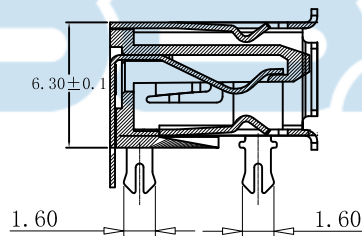

SECTION A-A

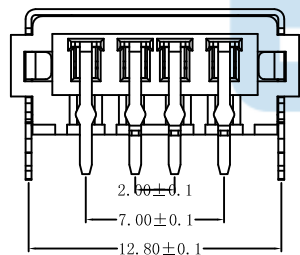
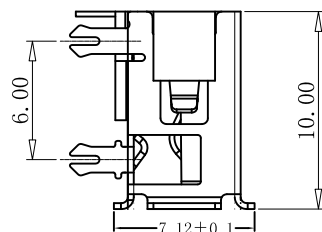
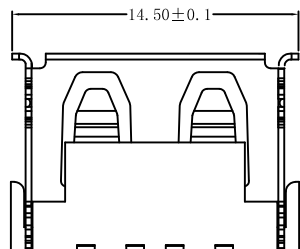

REV.	DESCRIPTION	NAME	DATE
A	NEWS ISSUE		

产品规格说明: (specifications)
电器特性: (Electrical characteristics)

- 接触阻抗: (Contact Resistance)
最大值30毫欧: (30 milliohms MAX)
- 耐电压: (Dielectric Withstanding Voltage):
500 伏特交流电 (500V AC AT Sea Level)
- 绝缘阻抗: (Insulation Resistance):
最小值1000兆欧姆 (1000 mega-ohms MIN)

机械性能: (Mechanical:)

- 插入力: (Insertion Force)
最大3.57kg (3.57kg MAX)
- 拔出力: (Unmating Force):
最少1.02kg (1.02 kg MIN)

材料: Material:

- 塑胶: (Housing) : LCP黑色
- 端子: (Contact): C2680
- 外壳: (Shell) : C2680/SPCC

电镀: (Finish):

- 端子(Contact): Au Plated ON Contact Area Over
30~60U Ni, Sn Plated On Solder Tails.
接触点镀金, 脚镀锡。
- 外壳: (Shell): Nickel Plating 镀亮镍80u''

TOLERANCE UNSPECIFIED

X . X	±0.30
X . XX	±0.20
X . XXX	±0.10
X °	±5°
X . X °	±2°

深圳市步步精科技有限公司

TITLE:
USB AF 90度 短体L=10.0 H=6.3 四脚插 (端子DIP) 卷边 LCP黑胶 铜壳

DRAWN/ DATE	设计 TSP	SIZE: A4	UNIT: MM.	PART. NO: UB.01.11-12-V004	
CHECKED/ DATE	审核 LYX	SCALE: 1:1	PROJECTION		REV.: 版本
APPROVED/ DATE	核准 LJP	DWG. PATH	0383-1		SHEET: 页码

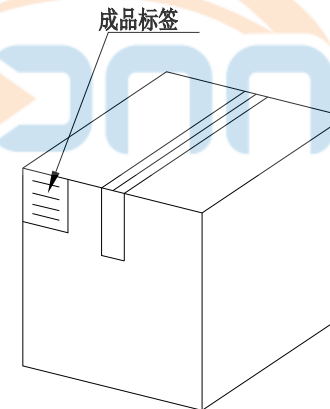
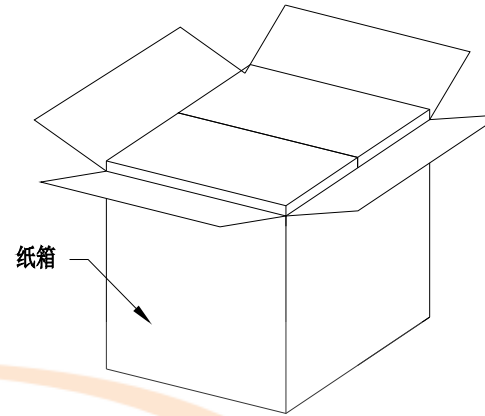
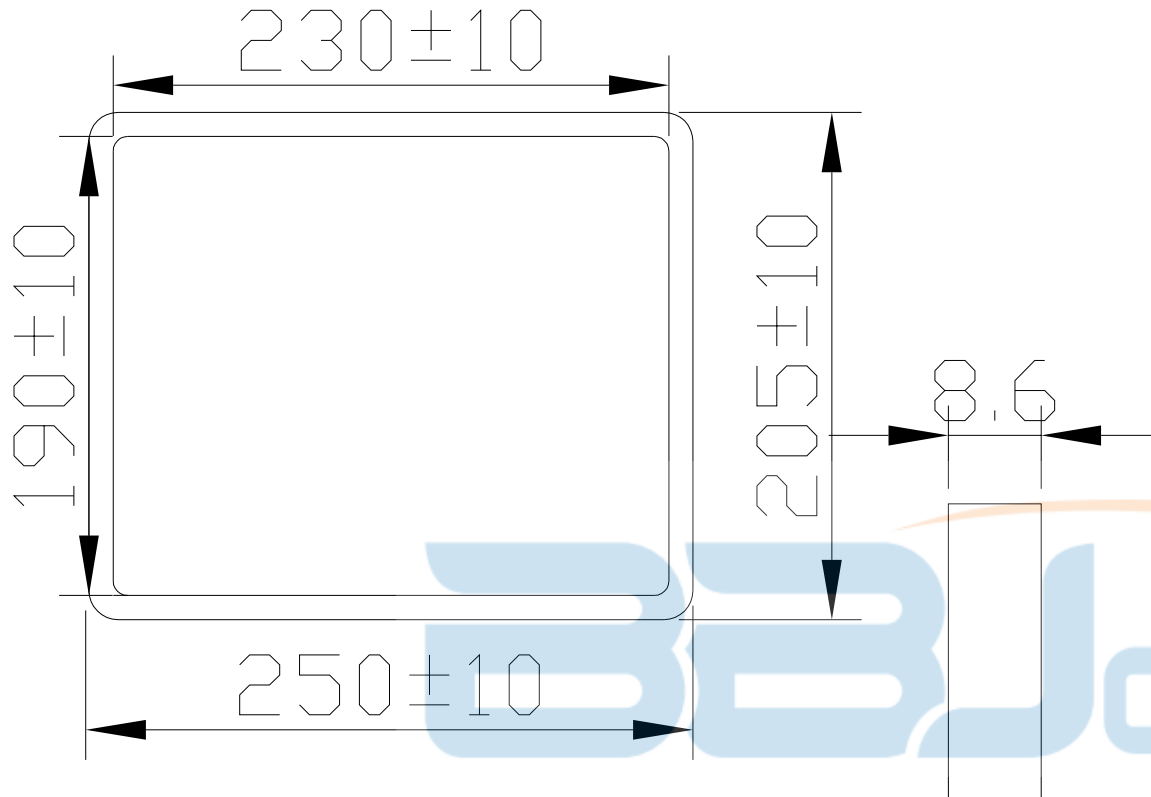

纸箱规格: 350*210*290

1. 包装要求:

- 1.1 每盒吸塑盒包装100 pcs;
- 1.2 每20盘放一箱, 共计2000PCS;
- 1.3 纸箱外贴上标签



TOLERANCE UNSPECIFIED		深圳市步步精科技有限公司 TITLE: USB AF 90度 短体L=10.0 H=6.3 四脚插 (端子DIP) 卷边 LCP黑胶 铜壳								
.0	±0.35									
.00	±0.25	DRAWN/ DATE		设计	TSP	SIZE: A4	UNIT: MM.	PART. NO: UB.01.11-12-V004		
.000	±0.15	CHECKED/ DATE		审核	LYX	SCALE: 1:1		PROJECTION	REV.: 版本	
X.°	±2.00°	APPROVED/ DATE		核准	LJP	DWG. PATH	0383-1		SHEET: 页码	
CUSTOMER DRAWING										