



REV.	DESCRIPTION	NAME	DATE
A	NEWS ISSUE		

特性: Specifications;

电器: Electyical;

接触阻抗: Contact Resistance
30 millionms MAX

耐电压: Dielectyic Withstanding Voltage:
500v AC AT Sea Level

绝缘阻抗: Insulation Resistance:
1000 MEGA ohms MLN

机构: Machanical;

接合为: Mating Force;

3.57 KG MAX 最大3.57Kg

拔出力: Unmating Force;

1.02KG MIN.最少1.02KG

材料: Matorial;

塑胶: Housing: High Temperatuye Thermoplastics
PBT/LCP

端子: Contact: Copper Alloy 铜合金

外壳: Shell: Copper Alloy spcc

电镀: Finish:

端子: Contact: Plated Gold in Mating
Area;

Tin/On Solder Tails

接触点镀金;脚镀锡50u

铁壳: Shell:

nickel Plating

镀镍 24H

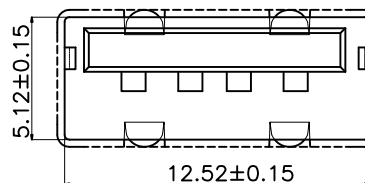
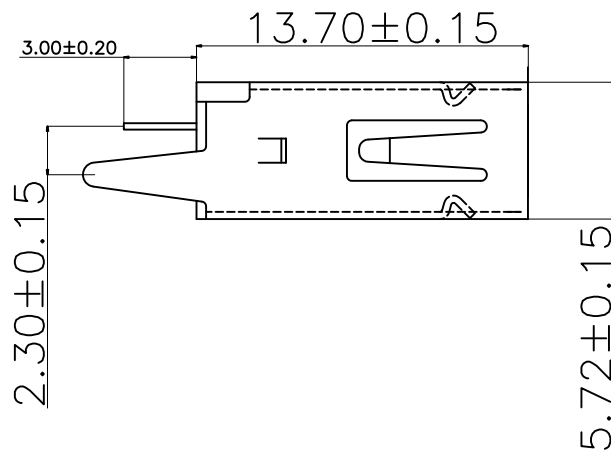
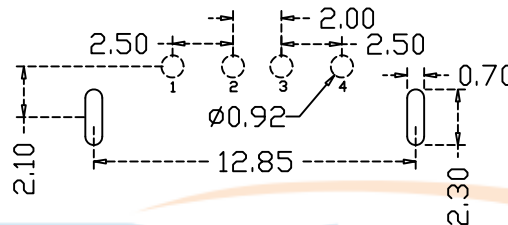
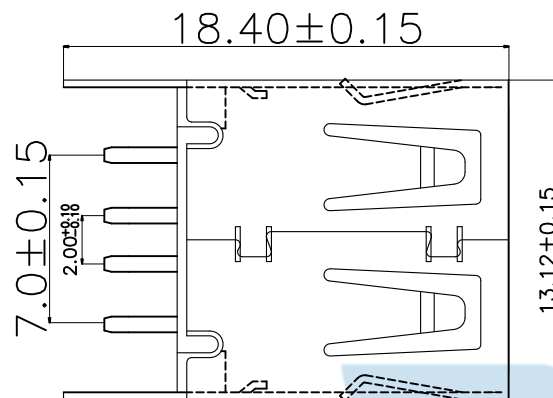

TOLERANCE UNSPECIFIED		深圳市步步精科技有限公司 TITLE: USB 2.0 AF 180度 直插直脚 H=13.70 平口 LCP蓝胶 铁壳			
.0	±0.35	SIZE: A4	UNIT: MM.	PART. NO: UB.01.12-31-V005	
.00	±0.25	CHECKED/ DATE	SCALE: 1:1	PROJECTION	REV.: 版本
.000	±0.15	APPROVED/ DATE	DWG. PATH	0383-1	SHEET: 页码
X. °	±2.00°	CUSTOMER DRAWING			

DRAWN/ DATE	设计 HMY	SIZE: A4	UNIT: MM.	PART. NO: UB.01.12-31-V005	
CHECKED/ DATE	审核 LYX	SCALE: 1:1	PROJECTION	REV.: 版本	
APPROVED/ DATE	核准 LJP	DWG. PATH	0383-1	SHEET: 页码	

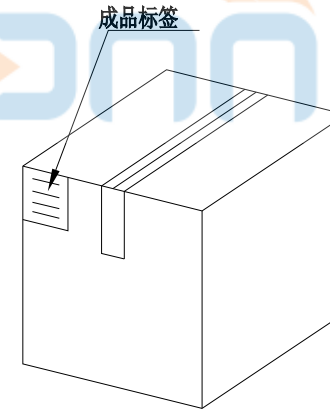
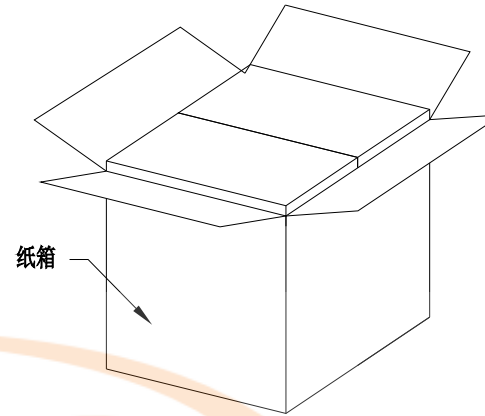
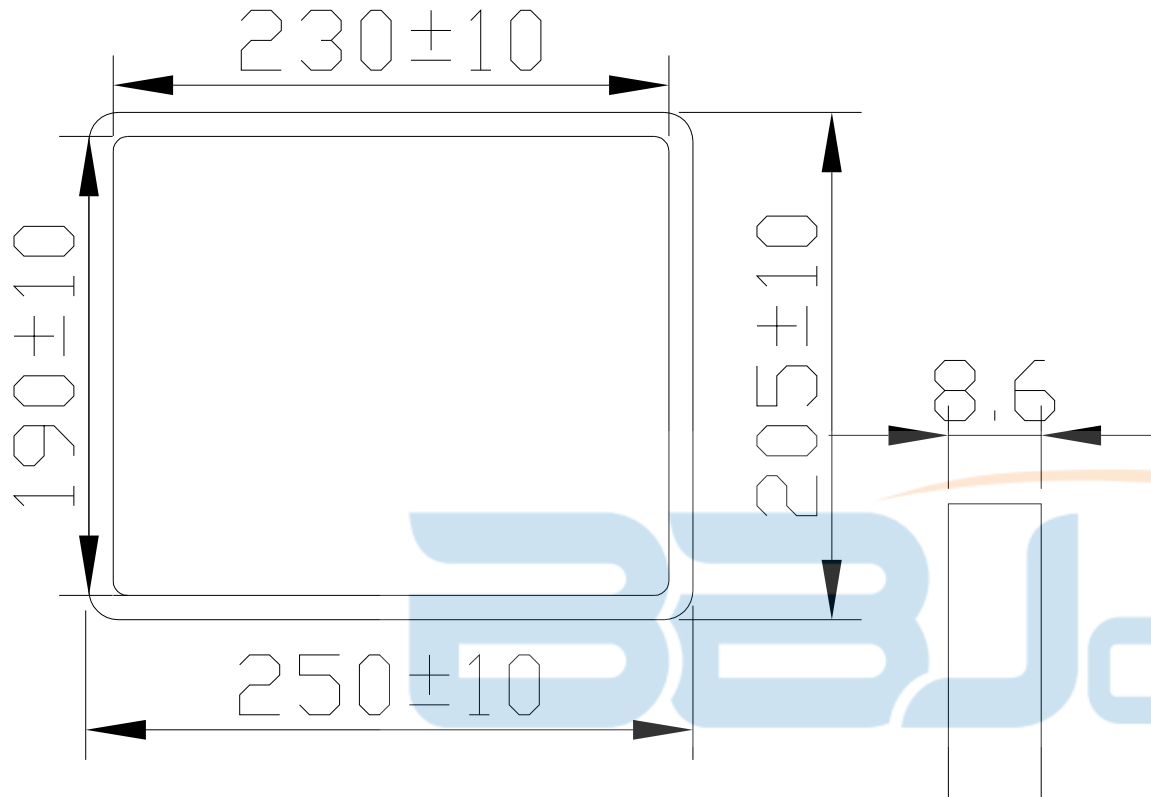

纸箱规格: 350*210*290

1. 包装要求:

- 1.1 每盒吸塑盒包装100pcs;
- 1.2 每20盘放一箱, 共计2000PCS;
- 1.3 纸箱外贴上标签



TOLERANCE UNSPECIFIED		深圳市步步精科技有限公司 TITLE: USB 2.0 AF 180度 直插直脚 H=13.70 平口 LCP蓝胶 铁壳			
.0	±0.35	SIZE: A4	UNIT: MM.	PART. NO: UB.01.12-31-V005	
.00	±0.25	DRAWN/ DATE		设计	HMJ
.000	±0.15	CHECKED/ DATE		审核	LYX
X. °	±2.00°	APPROVED/ DATE		核准	LJP
CUSTOMER DRAWING		DWG. PATH		0383-1	
		PROJECTION		REV.: 版本	
				SHEET: 页码	