

REV.	DESCRIPTION	NAME	DATE
A	NEWS ISSUE		

规格说明:Specifications:

电气特性:Electrical:

1. 额定电流: Current Rating
1.5A/contact terminal
2. 额定电压: Voltage Rating
30V DC
3. 接触阻抗:Contact Resistance
30 milliohms MAX
4. 耐电压:Dielectnic Withstanding Voitage:
500 V AC AT Sea Level
5. 绝缘阻抗:Insulation Resistance:
1000MEGA ohms MIN

物理性能:Mechanical:

1. 插拔力: Cnnector Mate and Unmate Force
Mate force:3.57kgf (MAX)
Unmate force:1.02kgf (MIN)
2. 端子保持力: Terminal Retenion
1.0kgf (MIN)

原材料:Material:

1. 塑胶:Housing:
Hing Temperature Thermoplastics,
2. 端子:Contact:Copper Alloy C2680
3. 外壳:Shell: Copper Alloy C2680/SPCC

电镀:Finish:

1. 端子:Contact: Piated Gold in Mating Area;
Tin On Solder Talls
2. 外壳:Shell:
铜壳四周镀80u" (MIN) 锡
Nickel Plating

公差一览表
.X±0.15 X.±5°
.XX±0.05 .X±2°
.XXX±0.02 XX±1°

深圳市步步精科技有限公司

TITLE: USB 2.0 母座 L=14.0 沉板1.8 破板3.9 外壳脚
前贴后插 鱼叉脚 (端子DIP) 卷边 LCP灰胶 铁壳

DRAWN/ DATE	设计 LYX	SIZE:A4	UNIT:MM.	PART.NO: UB.01.31-C1-3001	
CHECKED/ DATE	审核 HMY	SCALE: 1:1	PROJECTION		REV.: 版本
APPROVED/ DATE	核准 LJP	DWG. PATH	0020-1		SHEET: 页码

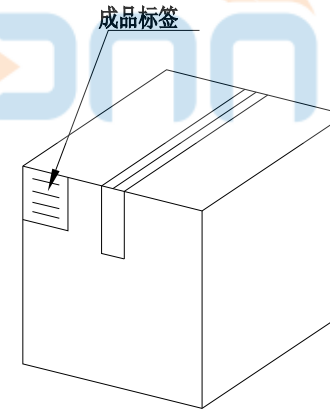
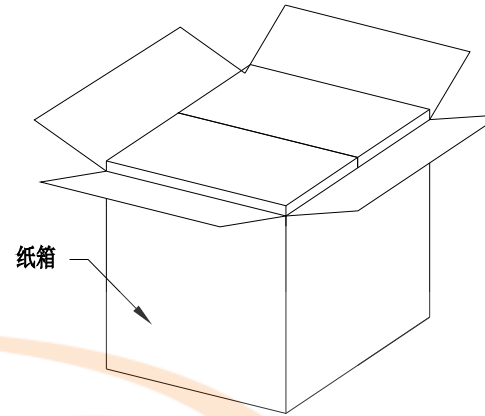
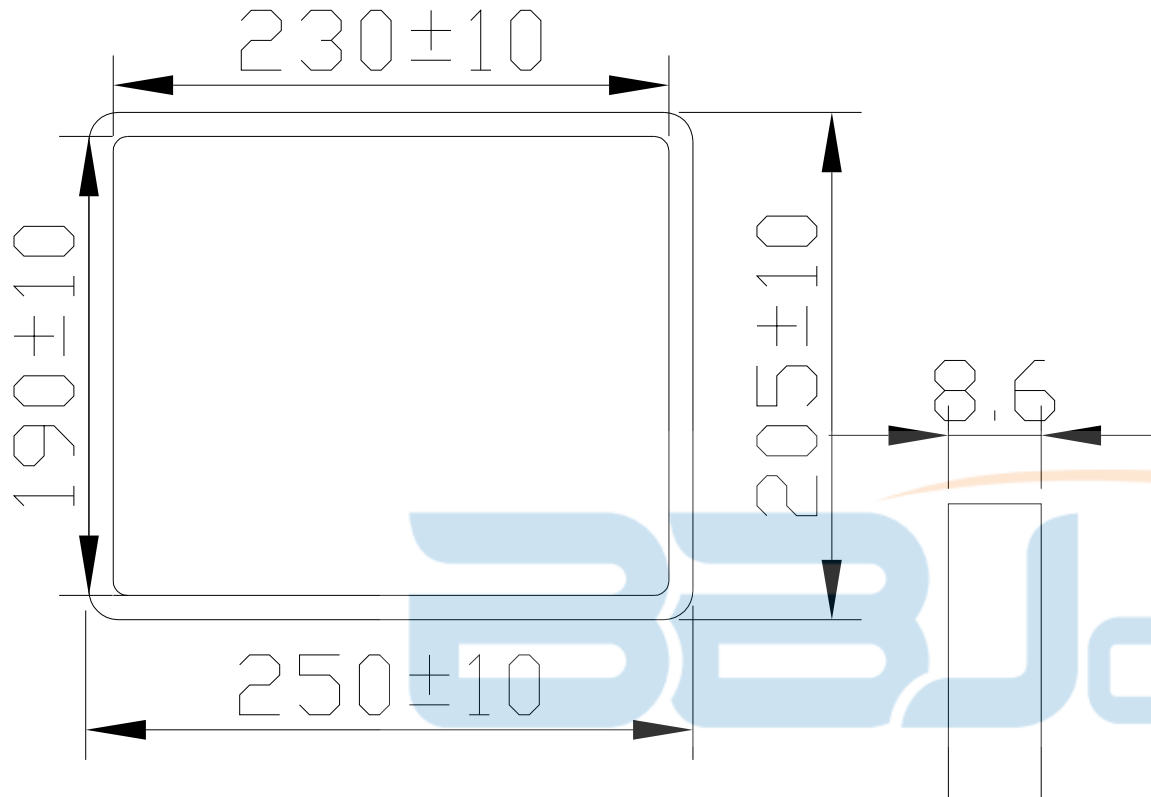

纸箱规格：350*210*290

1. 包装要求:

- 1.1 每盒吸塑盒包装100pcs;
- 1.2 每20盘放一箱，共计2000PCS;
- 1.3 纸箱外贴上标签



TOLERANCE UNSPECIFIED		深圳市步步精科技有限公司 TITLE: USB 2.0 母座 L=14.0 沉板1.8 破板3.9 外壳脚 前贴后插 鱼叉脚 (端子DIP) 卷边 LCP灰胶 铁壳								
.0	±0.35									
.00	±0.25	DRAWN/ DATE		设计	LYX	SIZE: A4	UNIT: MM.	PART. NO: UB.01.31-C1-3001		
.000	±0.15	CHECKED/ DATE		审核	HMY	SCALE: 1:1		PROJECTION	REV.: 版本	
X.°	±2.00°	APPROVED/ DATE		核准	LJP	DWG. PATH	0020-1		SHEET: 页码	
CUSTOMER DRAWING										