

Pin NUMBER	SIGNAL NAME
1	VBUS
2	D-
3	D+
4	GND
5	StdA_SSRX-
6	StdA_SSRX+
7	GND_DRAIN
8	StdA_SSTX-
9	StdA_SSTX+
Shell	Shield

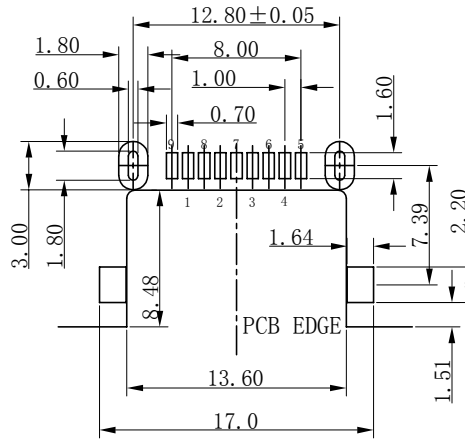

RECOMMENDED PCBA LAYOUT  
(TOLERANCE ± 0.05)

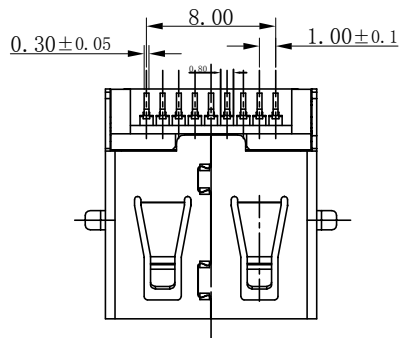
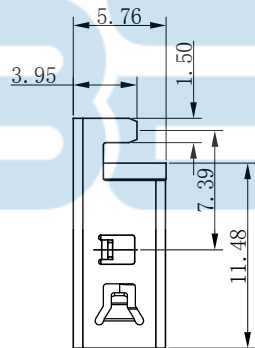

REV.	DESCRIPTION	NAME	DATE
A	NEWS ISSUE		

NOTE:

1. MATERIAL:

- 1.1 INSULATOR: LCP UL 94V-0
- 1.2 CONTACT: BRONZE (T=0.20mm)
- 1.3 SHELL: BRASS (T=0.30mm)

2. ELECTRICAL CHARACTERISTICS:

- 2.1 CONTACT RESISTANCE: 30mΩ MAXIMUM
- 2.2 CONTACT CURRENT RATING: 1.5A
- 2.3 DIELECTRIC WITHSTANDING VOLTAGE: 500 V R. M. S.
- 2.4 INSULATION RESISTANCE 1000 MEGOHMS MIN
- 2.5 OPERATING TEMPERATURE: -40° C ~ 85° C

3. MECHANICAL CHARACTERISTICS:

- 3.1 MATING FORCE: 3.57kg MAX
- 3.2 UNMATED FORCE: 1.02kg MIN
- 3.3 DURABILITY: MANDATORY: 5,000 CYCLES

4. PLATING

4.1 TERMINAL:

- 50u" MIN NICKEL ALL OVER
- 100u" MIN Tin ON SOLDER AREA
- (1~30)u" Au ON CONTACT AREA

4.2 SHELL: 100u" MIN. NICEL ALL OVER

5. " " FOR MAJOR DIM



NO.	DESCRIPTION	MATERIAL	QTY.	REMARK
③	SHELL	COPPER ALLOY / 不锈钢	1	Ni PLATED
②	CONTACT FOOT 1#	COPPER ALLOY	9	GOLD/TIN PLATED Ep/Sn Sn 100u" Min EP/Au AU 1u"
①	HOUSING	LCP (BLACK) / (BLUE)	1	UL94V-0

TOLERANCE UNSPECIFIED  
X.X ± 0.30  
X.XX ± 0.20  
X.XXX ± 0.10  
ANG. ± 5°  
CUSTOMER DRAWING

**BBJconn** 深圳市步步精科技有限公司

TITLE: USB 3.0 AF 90度 前两脚贴 后两脚插 正向沉板2.45  
L=14.25 H=5.76 平口 端子SMT LCP蓝 铜壳 (盒装)

DRAWN/ DATE	设计	ZY	SIZE: A4	UNIT: MM.	PART. NO: UB.03.52-32-W006	REV.: 版本
CHECKED/ DATE	审核	LYX	SCALE: 1:1	PROJECTION		SHEET: 页码
APPROVED/ DATE	核准	LJP	DWG. PATH	0540-1		



REV.	DESCRIPTION	NAME	DATE
A	NEWS ISSUE		

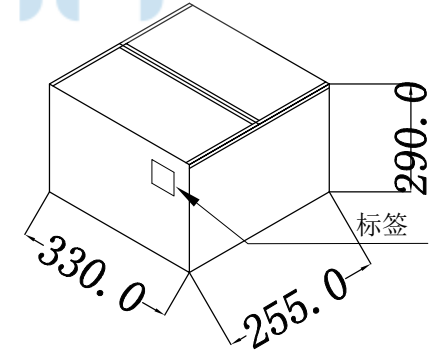
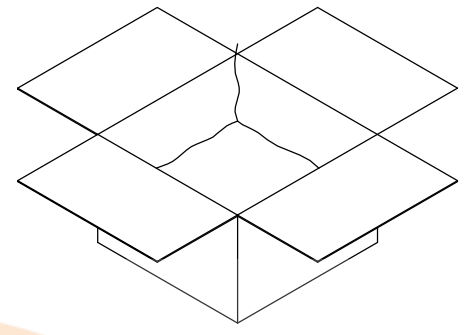

备注:  
 1. 吸塑盒规格: 310\*220\*8.3; 纸箱规格: 330\*255\*290  
 2. 100PCS/盘; 3000PCS/箱

TOLERANCE UNSPECIFIED		深圳市步步精科技有限公司 TITLE: USB 3.0 AF 90度 前两脚贴 后两脚插 正向沉板2.45 L=14.25 H=5.76 平口 端子SMT LCP蓝 铜壳 (盒装)					
X.X	±0.30						
X.XX	±0.20	CUSTOMER DRAWING					
X.XXX	±0.10	DRAWN/ DATE	设计 ZY	SIZE:A4	UNIT:MM.	PART.NO: UB.03.52-32-W006	
ANG.	± 5	CHECKED/ DATE	审核 LYX	SCALE: 1:1	PROJECTION	REV.: 版本	
		APPROVED/ DATE	核准 LJP	DWG. PATH	0540-1	SHEET: 页码	