



NOTES:

1. MATERIAL

CONTACTS: COPPER ALLOY C2680 (T=0.25mm)
 SHELL: COPPER ALLOY C2680(T=0.40mm)
 HOUSING: PBT UL94V-0 Blue

2. ELECTRICAL PERFORMANCE,

CONTACT RESISTANCE: 30MΩ MAX
 CONTACT CURRENT RATING: 1.00 AMPERES
 DIELECTRIC WITHSTAND VOLTAGE, 100V R.M.S
 INSULATION RESISTANCE: 100MΩ MIN
 OPERATING TEMPERATURE: -40° C~+85° C.

3. MECHANICAL PERFORMANCE,

INSERTION FORCE: 3.57 kgf Max
 REMOVAL FORCE: 0.81 kgf Min
 DURABILITY: 5000 CYCLES.

4. PLATING SPECIFICATION:

CONTACTS: GOLD PLATED ON CONTACT AREA,
 100-200u'' Sn ON SOLDER AREA,
 50-100u'' NICKEL UNDERPLATED.

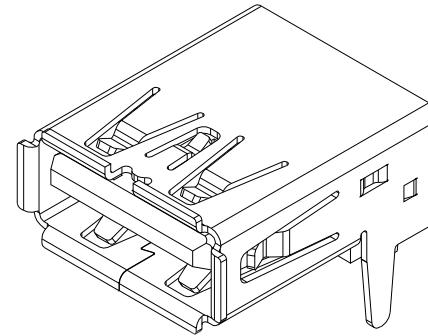
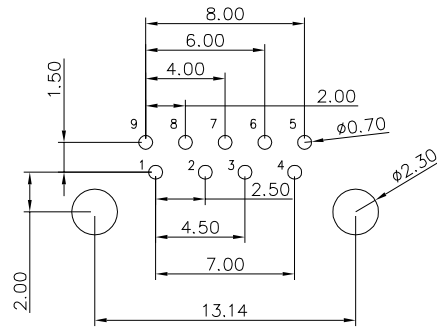
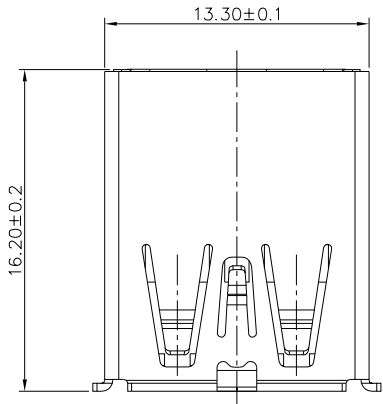

CONNECTOR FRONT EDGE
 REFERENCE PCB LAYOUT

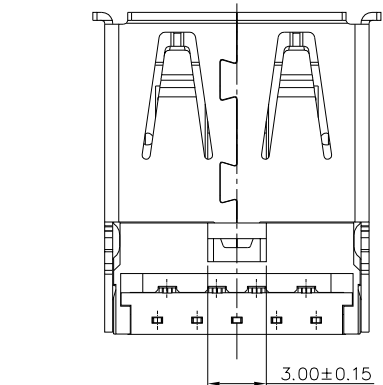
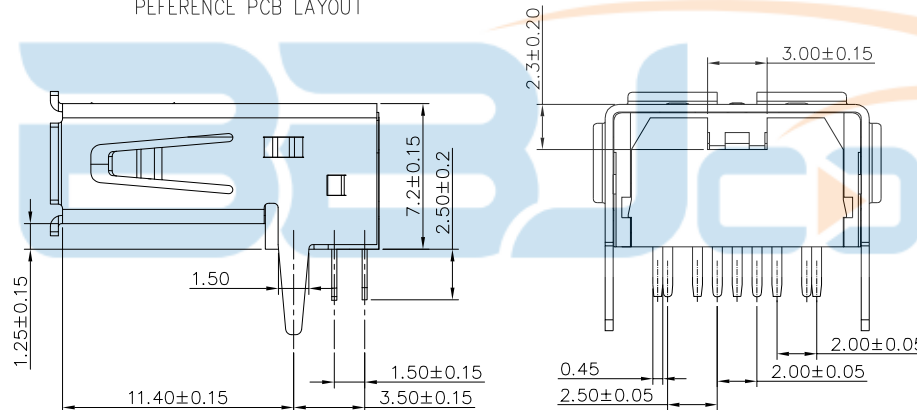
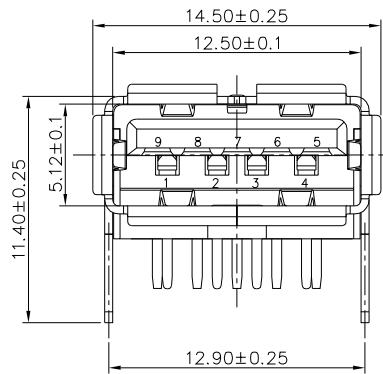

Pin Number	Signal Name
1	VBUS
2	D-
3	D+
4	GND
5	StdA_SSRX-
6	StdA_SSRX+
7	GND_DRAIN
8	StdA_SSTX-
9	StdA_SSTX+
Shell	Shield

TOLERANCE UNSPECIFIED	
.0	±0.35
.00	±0.25
.000	±0.15
X.°	±2.00°
CUSTOMER DRAWING	
DRAWN	HMY
DATE	
CHECKED	YDH
DATE	
APPROVED	LJP
DATE	

深圳市步步精科技有限公司			
TITLE: USB 3.0 母座 板上型 L=16.2 直脚 卷边 PBT蓝胶 铜壳 外壳脚宽度尺寸1.5mm			
SIZE: A4	UNIT: mm.	PART. NO: UB.11.11-32-1001	
SCALE: 1:1	PROJECTION	REV.: A	
DWG	PATH	0100-2	PATH 1/2

一、將成品依同一方向放入真空盤內, 如圖所示。

At same direction, put product onto the tray. Direction refers to below drawing.

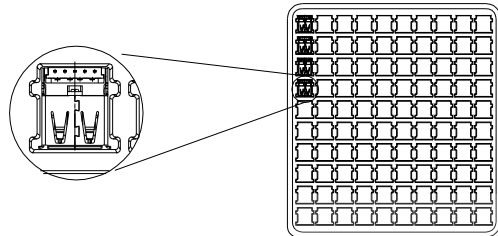

VIEW-1



3) 將裝滿成品的真空盤用 PE帶捆緊後放在塑膠袋內, 裝完後再封箱。

3) Bind the trays with PE tape and then, put them into the poly bag. Seal the carton with tape.

三、1). 將標籤貼於紙箱側麥上方。

Stick the needful label On the up-right corner of the side of carton.

標籤黏貼處
Location of Sticking lable

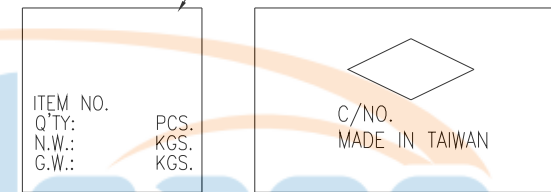

VIEW-3

二、

1) 一只紙箱可放置之包裝盤(包括上蓋)見下表。

1) trays per carton, please see next table.

2). 每1個紙箱用的包裝數量詳見下表。

2) The Q'ty of products per carton please see next tabel.

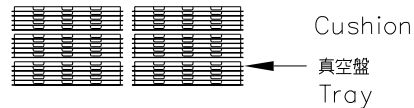

VIEW-2

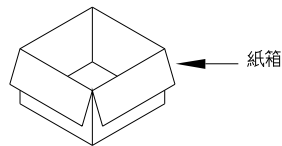

備註 (REMARK)

- 若有未裝滿之零數箱, 必須以緩衝材塞滿
The unfilling-carton must be filled with assuagement.
- 裝滿成品后之外箱, 最大堆積箱數: 5箱
About the box fully filled with products, the MAX accumulating quantity of boxes is 5.
- 如須貼Bar-code, 請依Bar-code作業辦法執行
If barcode lable is required, do it according to the related barcode lable operation standards.

包裝明細表 (The detail of the packing)

產品料號 (Product No.)	包裝容量 (Packing Capacity)			重量 Weight (Kg)		
	pcs/box	boxs/Carton	Pcs/Box	N.W./Pcs	N.W./Box	G.W./Box
	100	30	3000			

TOLERANCE UNSPECIFIED	
.0	±0.35
.00	±0.25
.000	±0.15
X.°	±2.00°
CUSTOMER DRAWING	

深圳市步步精科技有限公司

TITLE: USB 3.0 母座 板上型 L=16.2 直脚 卷边
PBT蓝胶 铜壳 外壳脚宽度尺寸1.5mm

DRAWN DATE	HMY	SIZE: A4	UNIT: mm.	PART. NO: UB.11.11-32-1001	
CHECKED DATE	YDH	SCALE: 1:1	PROJECTION		REV.: A
APPROVED DATE	LJP	DWG PATH	0100-2	PATH 2/2	