

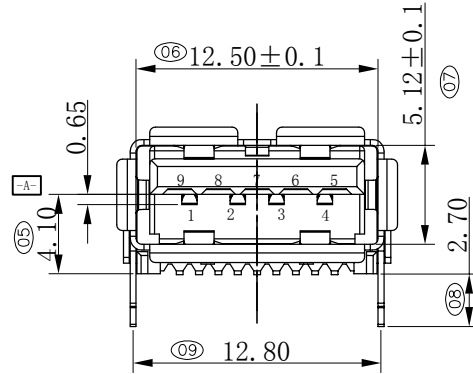

REV.	DESCRIPTION	NAME	DATE
A	NEWS ISSUE		

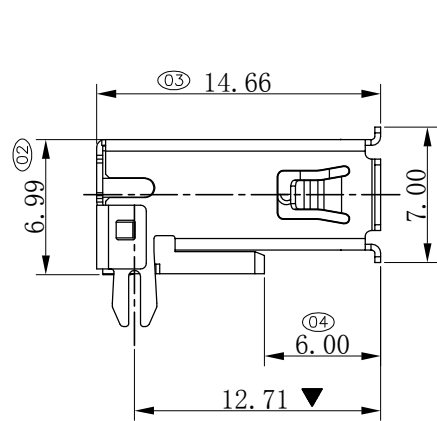

- NOTE:
- MATERIAL:
 - INSULATOR: LCP UL 94V-0
 - CONTACT: BRONZE (T=0.20mm)
 - SHELL: BRASS (T=0.30mm)
 - ELECTRICAL CHARACTERISTICS:
 - CONTACT RESISTANCE: 30mΩ MAXIMUM
 - CONTACT CURRENT RATING: 1.5A
 - DIELECTRIC WITHSTANDING VOLTAGE: 500 V R.M.S.
 - INSULATION RESISTANCE: 1000 MEGOHMS MIN
 - OPERATING TEMPERATURE: -40° C ~ 85° C
 - MECHANICAL CHARACTERISTICS:
 - MATING FORCE: 3.57kg MAX
 - UNMATED FORCE: 0.82kg MIN
 - DURABILITY: MANDATORY: 15,000 CYCLES
 - PLATING:
 - TERMINAL:
 - 50u" MIN NICKEL ALL OVER
 - 100u" MIN TIN ON SOLDER AREA
 - 1"30u" Au ON CONTACT AREA
 - SHELL: 50u" MIN. NICKEL ALL OVER

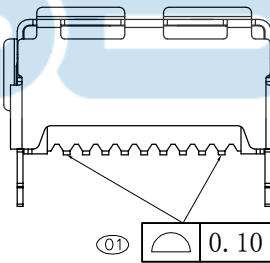
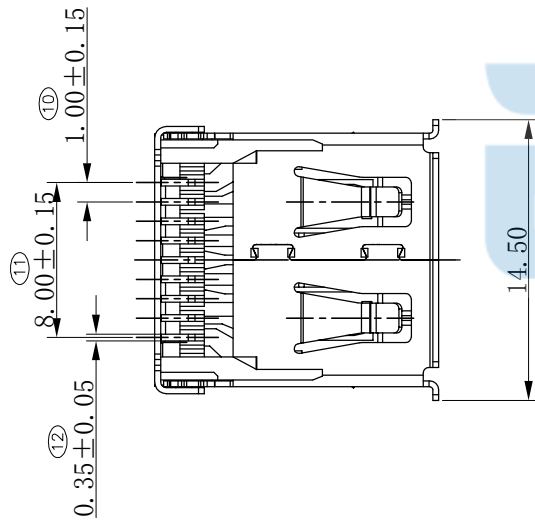

Pin NUMBER	SIGNAL NAME
1	VBUS
2	D-
3	D+
4	GND
5	StdA_SSRX-
6	StdA_SSRX+
7	GND_DRAIN
8	StdA_SSTX-
9	StdA_SSTX+
Shell	Shield

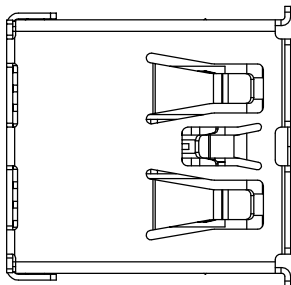
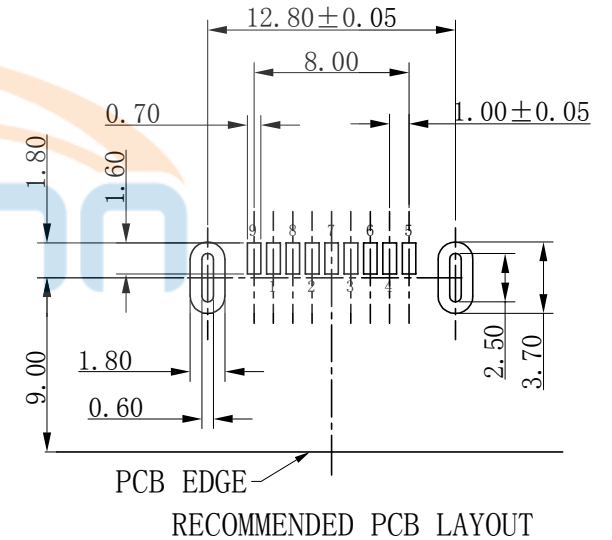

TOLERANCE UNSPECIFIED	
X.X	±0.30
X.XX	±0.20
X.XXX	±0.10
ANG.	±° 5
CUSTOMER DRAWING	

深圳市步步精科技有限公司

TITLE:
USB 3.0 AF 90度 后两脚插 鱼叉脚 短体 L=14.66 H=6.99 端子SMT 卷边 LCP蓝胶 铜壳

DRAWN/ DATE	设计 ZY	SIZE:A4	UNIT:MM.	PART.NO:	UB.03.51-32-W002
CHECKED/ DATE	审核 LYX	SCALE: 1:1	PROJECTION	⊕	REV.: 版本
APPROVED/ DATE	核准 LJP	DWG. PATH	0540-1	SHEET: 页码	



REV.	DESCRIPTION	NAME	DATE
A	NEWS ISSUE		

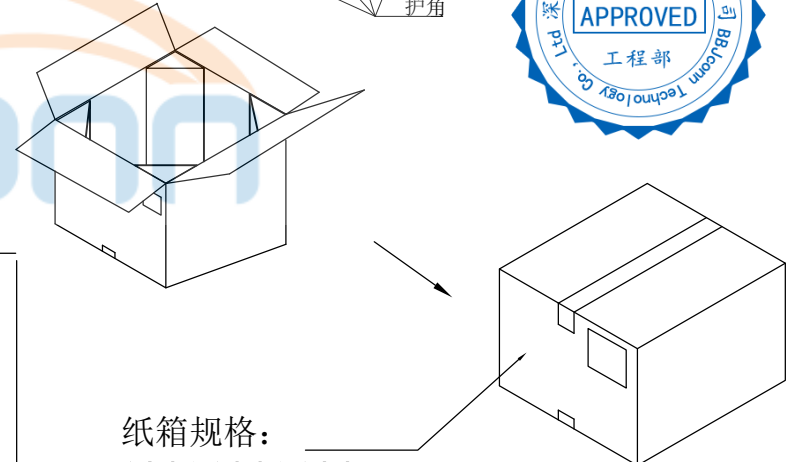
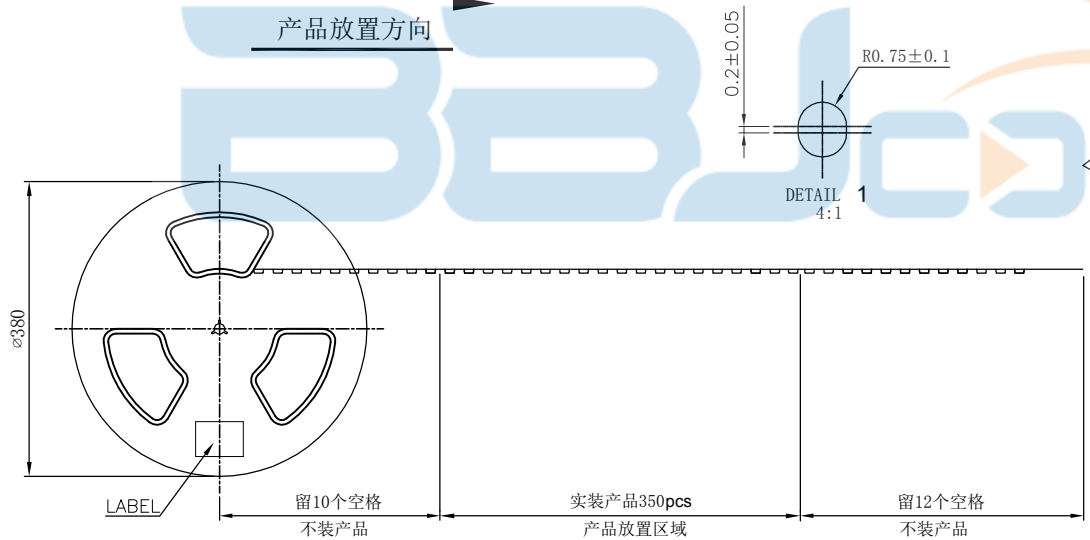
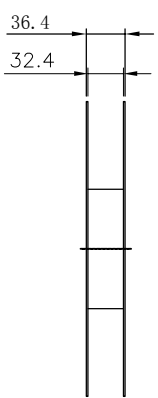
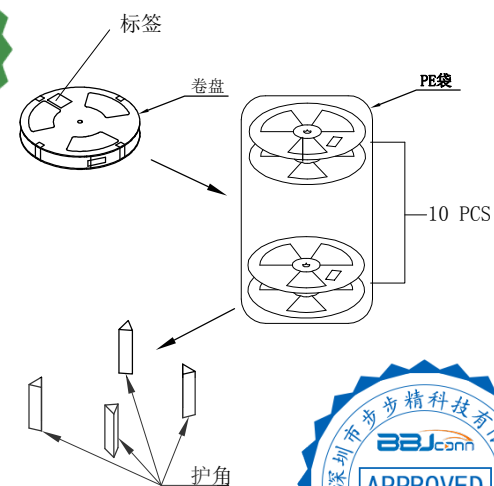
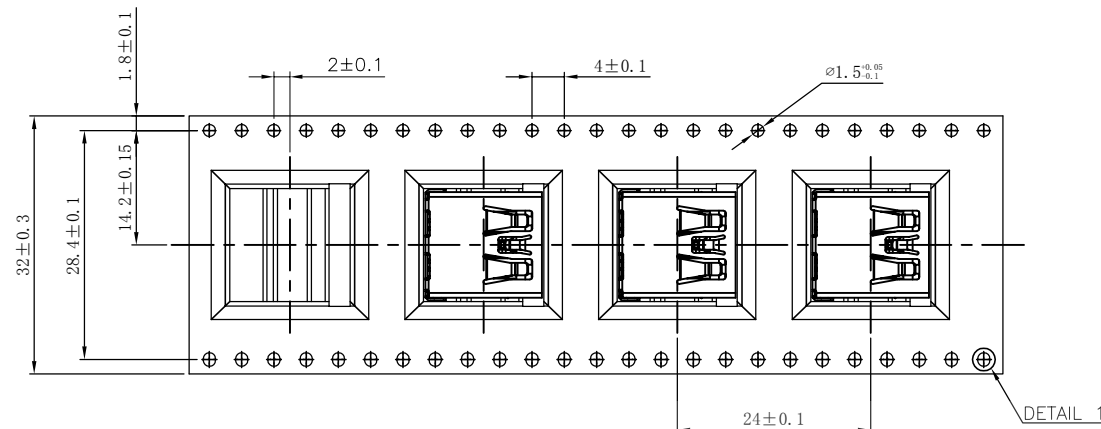

纸箱规格:
400*400*400

NOTE:

- MATERIAL:
BOX: FIBREBOARD, CORRUGATED, DOUBLE WALL.
TAPE: POLYSTYRENES, HEAT-RESISTANT TEMPERATURE: 120°C, BLACK COLOR.
REEL: POLYSTYRENES, HEAT-RESISTANT TEMPERATURE: 70°C, BLUE COLOR.
BAG: POLYETHYLENE, HEAT-RESISTANT TEMPERATURE: 100°C.
- PEELING STRENGTH: 0.1 ~ 1.3 N (10 ~ 130 GRAMS)
- PEELING SPEED: 300 mm/min.
- EACH BAG SHALL BE INCLUDED DESICCANT.

放料方向

TOLERANCE UNSPECIFIED		深圳市步步精科技有限公司 TITLE: USB 3.0 AF 90度 短体 L=14.66 H=6.99 端子SMT 卷边 LCP蓝胶 铜壳	
X.X	±0.30		
X.XX	±0.20		
X.XXX	±0.10		
ANG. ±° 5		CUSTOMER DRAWING	
DRAWN/ DATE	设计 ZY	SIZE:A4	UNIT:MM. PART.NO: UB.03.51-32-W002
CHECKED/ DATE	审核 LYX	SCALE: 1:1	PROJECTION REV.: 版本
APPROVED/ DATE	核准 LJP	DWG. PATH	0540-1 SHEET: 页码