

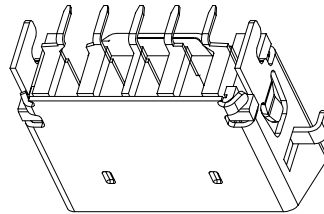

REV.	DESCRIPTION	NAME	DATE
A	NEWS ISSUE		

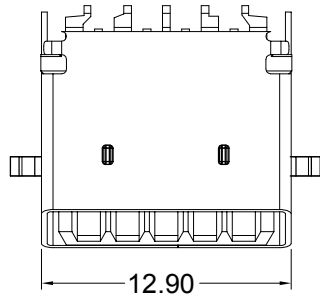

- NOTE:
- MATERIAL:
 - INSULATOR:HIGH TEMPERATURE PLASTIC UL 94 V-0;
 - CONTACT: COPPER ALLOY(T=0.2mm)
 - SHELL:SUS201(T=0.30mm)
 - ELECTRICAL CHARACTERISTICS:
 - CONTACT RESISTANCE:30m Max
 - CONTACT CURRENT RATING:1.5A
 - DIELECTRIC WITHSTANDING VOLTAGE:500 V R.M.S.
 - INSULATION RESISTANCE 100 MEGOHMS M
 - OPERATING TEMPERATURE:-40°C - 85°C
 - RATE VOLTAGE: 30V DC
 - MECHANICAL CHARACTERISTICS:
 - MATING FORCE:10 N Min INITIAL; 8 N Min AFTER TEST
 - UNMATED FORCE:35 N Max
 - DURABILITY:5,000 CYCLES
 - PLATING
 - TERMINAL CONTACT:GOLD PLATING ALL OVER
50u* MIN NICKEL AND 80u*MIN Matte Tin
NICKEL IN SOLDER AREA(SEE TAB)
 - SHELL:50u*MIN. NICKEL ALL OVER

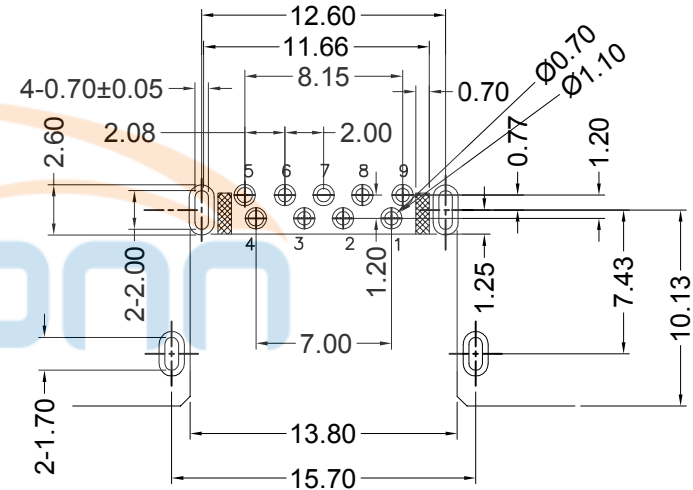
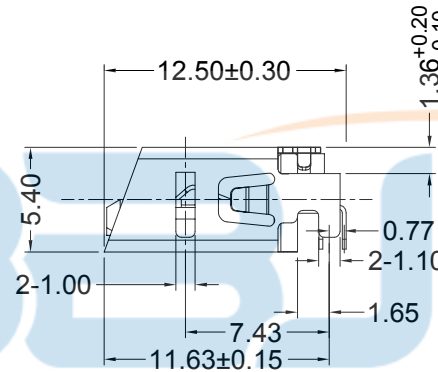
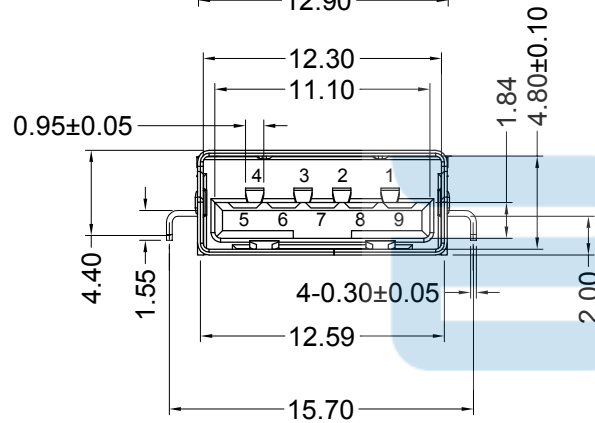

TOLERANCE: ±0.05, THICKNESS: 1.0~1.2mm
 RECOMMENDED PCB LAYOUT
 (TOP VIEW)
 KEEP OUT AREA

Pin #	SIGNAL NAME	DESCRIPTION	MATING SEQUENCE
1	VBUS	POWER	SECOND
2	D-	USB 2.0 DIFFERENTIAL PAIR	THIRD
3	D+	USB 2.0 DIFFERENTIAL PAIR	THIRD
4	GND	GROUND FOR POWER RETURN	SECOND
5	StdA_SSRX-	SUPERSEED RECEIVER DIFFERENTIAL PAIR	LAST
6	StdA_SSRX+	SUPERSEED RECEIVER DIFFERENTIAL PAIR	LAST
7	GND_DRAIN	GROUND FOR SIGNAL RETURN	
8	StdA_SSTX-	SUPERSEED TRANSMITTER DIFFERENTIAL PAIR	
9	StdA_SSTX+	SUPERSEED TRANSMITTER DIFFERENTIAL PAIR	
Shell	Shield	CONNECTOR METAL SHELL	FIRST

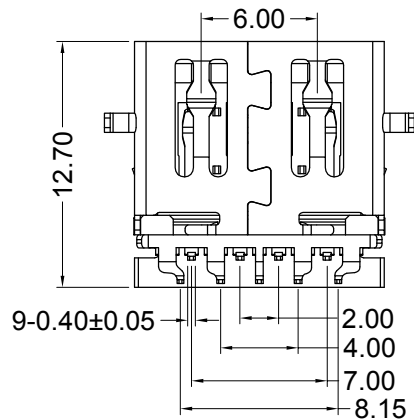

TOLERANCE UNSPECIFIED X.X ±0.30 X.XX ±0.20 X.XXX ±0.10 ANG. ±° 5 CUSTOMER DRAWING		深圳市步步精科技有限公司 TITLE: USB 3.0 AF 90度 四脚插 斜平口 沉板2.0 L=12.50mm H=5.40 端子DIP LCP蓝胶 不锈钢壳			
DRAWN/ DATE	设计 ZY	SIZE:A4	UNIT:MM.	PART.NO: UB.03.12-33-W008	
CHECKED/ DATE	审核 LYX	SCALE: 1:1		PROJECTION	REV.: 版本
APPROVED/ DATE	核准 LJP	DWG. PATH	0540-1		SHEET: 页码



REV.	DESCRIPTION	NAME	DATE
A	NEWS ISSUE		

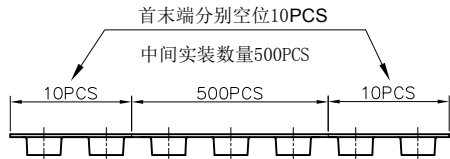

* 载带包装时请依此引出方向为标准

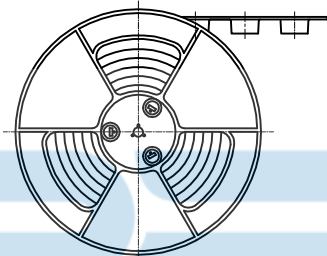
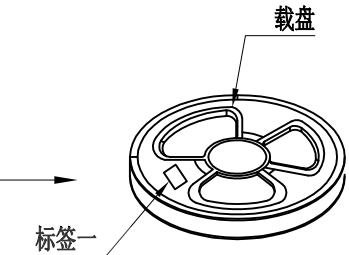
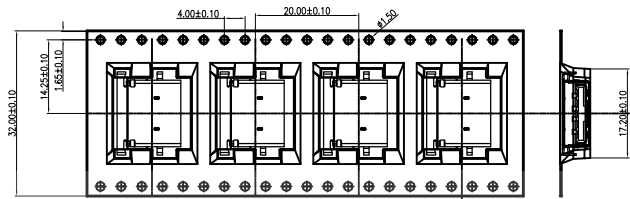
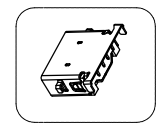

1载带=500PCS
1外箱=500PCSX8盘载带=4000PCS

备注:

1. 每箱内必须放干燥剂;
2. 每箱必须用PE带密封包装;
3. 参考《高温材料管理规定》进行作业;
4. 我司标准格式标签或标签按客户要求制作;

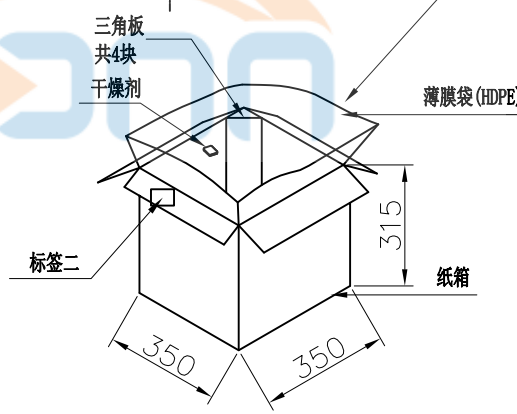

包材名称	材料及厚度(mm)	规格(mm)
USB3.1 载带	P.S(白色透明) T=0.40	500X24.00X5.95
载盘	HI P.S(蓝色)	∅330X36.40
自粘带	PET(白色透明)	W=25.30 T=0.06
PE-375X450X0.06-A	PE(白色透明)	770X750X0.035
ZK-400X400X330-A	K=K t=4	350X350X315
三角板	A=A+ t=4	260X300

TOLERANCE UNSPECIFIED		X.X ±0.30		深圳市步步精科技有限公司 TITLE: USB 3.0 AF 90度 四脚插 斜平口 沉板2.0 L=12.50mm H=5.40 端子DIP LCP蓝胶 不锈钢壳	
		X.XX ±0.20			
		X.XXX ±0.10			
		ANG. ±° 5			
		CUSTOMER DRAWING			
DRAWN/ DATE	设计 ZY	SIZE:A4	UNIT:MM.	PART. NO: UB.03.12-33-W008	
CHECKED/ DATE	审核 LYX	SCALE: 1:1	PROJECTION		REV.: 版本
APPROVED/ DATE	核准 LJP	DWG. PATH	0540-1		SHEET: 页码