

RECOMMENDED PCBA LAYOUT  
(TOLERANCE  $\pm 0.05$ )

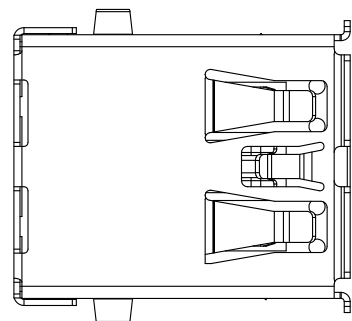
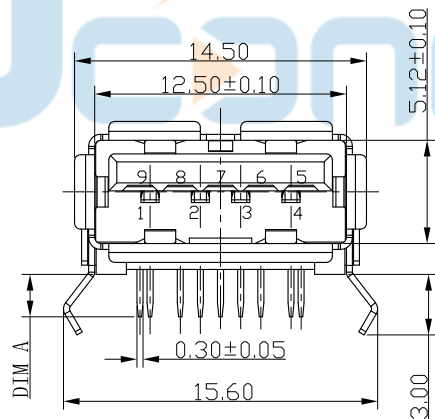
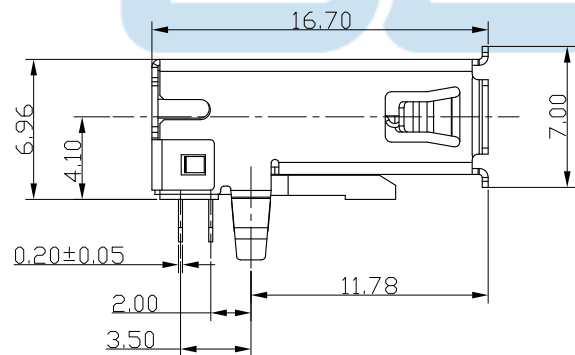

REV.	DESCRIPTION	NAME	DATE
A	NEWS ISSUE		

NOTE:

- MATERIAL:
  - INSULATOR: HIGH TEMPERATURE PLASTIC
  - CONTACT: BRONZE
  - SHELL: BRASS/SUS201
- ELECTRICAL CHARACTERISTICS:
  - CONTACT RESISTANCE: 30mΩ MAX
  - CONTACT CURRENT RATING: 1.5A
  - DIELECTRIC WITHSTANDING VOLTAGE: 100 V R. M. S.
  - INSULATION RESISTANCE 100 MΩ MIN
  - OPERATING TEMPERATURE: -40° C ~ 85° C
- MECHANICAL CHARACTERISTICS:
  - MATING FORCE: 3.57kgf MAX
  - UNMATING FORCE: 1.02kgf MIN
  - DURABILITY: MANDATORY: 1,500 CYCLES
- PLATING
  - TERMINAL:
    - 50u" MIN NICKEL ALL OVER
    - 100u" MIN Tin ON SOLDER AREA
    - (1~30)u" Au ON CONTACT AREA
  - SHELL: 50u" MIN. NICEL ALL OVER

DIMA
2.10
2.30
2.50

Pin NUMBER	SIGNAL NAME
1	VBUS
2	D-
3	D+
4	GND
5	StdA_SSRX-
6	StdA_SSRX+
7	GND_DRAIN
8	StdA_SSTX-
9	StdA_SSTX+
	ShellShield

TOLERANCES UNLESS  
 X.  $\pm 0.30$  X°  $\pm 3^\circ$   
 .X  $\pm 0.20$  .X°  $\pm 2^\circ$   
 .XX  $\pm 0.20$  .XX°  $\pm 1^\circ$   
 .XXX  $\pm 0.10$  .XXX°  $\pm 0.5^\circ$

**深圳市步步精科技有限公司**

TITLE: USB 3.0 AF 90度 L=16.70 H=6.96 后两脚插 弯脚 (端子DIP) 端子脚长2.10 卷边 LCP蓝胶 不锈钢外

DRAWN/ DATE	设计 TSP	SIZE: A4	UNIT: MM.	PART. NO:	UB.01.11-33-W001
CHECKED/ DATE	审核 LYX	SCALE: 1:1	PROJECTION	REV.:	版本
APPROVED/ DATE	核准 LJP	DWG. PATH		0471-1	SHEET: 页码

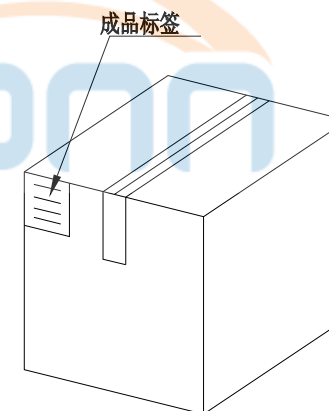
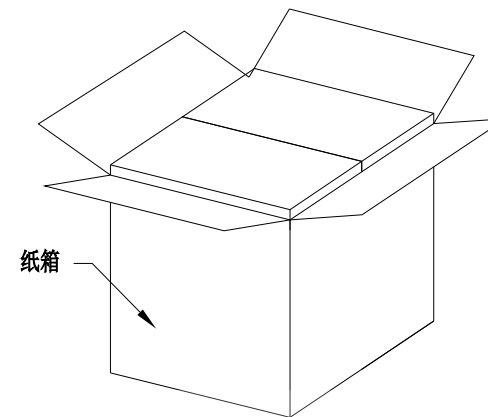
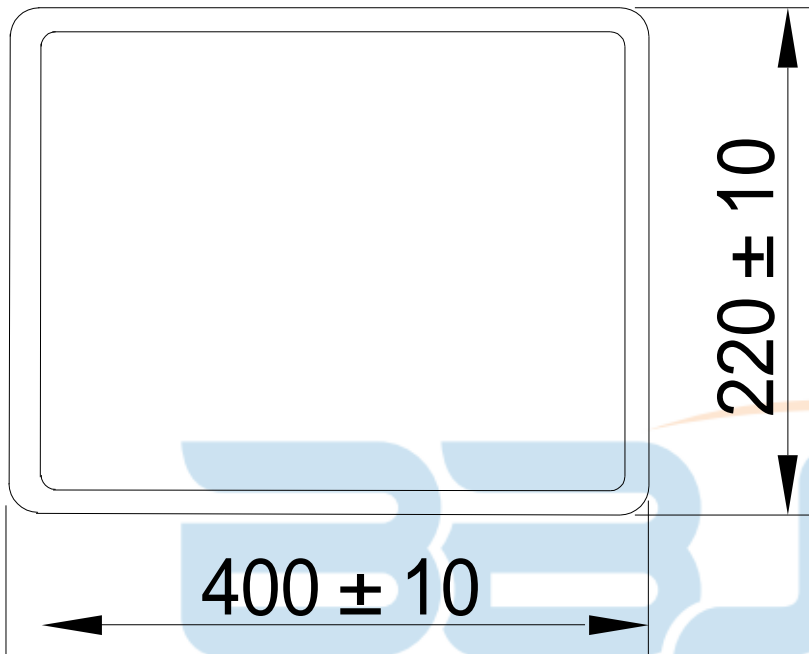

纸箱规格: 350\*210\*290

1. 包装要求:

- 1.1 每盒吸塑盒包装100 pcs;
- 1.2 每20盘放一箱, 共计2000PCS;
- 1.3 纸箱外贴上标签



TOLERANCES UNLESS		深圳市步步精科技有限公司			
X. ± 0.30 X° ± 3°		TITLE: USB 3.0 AF 90度 L=16.70 H=6.96 后两脚插 弯脚			
.X ± 0.20 .X° ± 2°		(端子DIP) 端子脚长2.10 卷边 LCP蓝胶 不锈钢外壳 端子镀金G-F			
.XX ± 0.20 .XX° ± 1°		SIZE: A4	UNIT: MM.	PART. NO: UB.01.11-33-W001	
.XXX ± 0.10 .XXX° ± 0.5°		CHECKED/ DATE	SCALE: 1:1	PROJECTION	REV.: 版本
DRAWN/ DATE	设计 TSP	APPROVED/ DATE	DWG. PATH	0471-1 SHEET: 页码	
	审核 LYX				
	核准 LJP				