

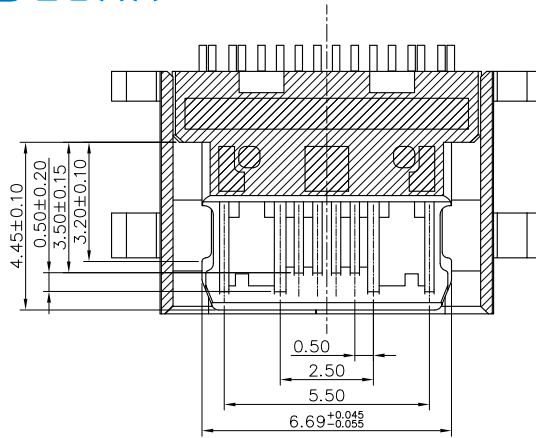

REV.	DESCRIPTION	NAME	DATE
A	NEWS ISSUE		

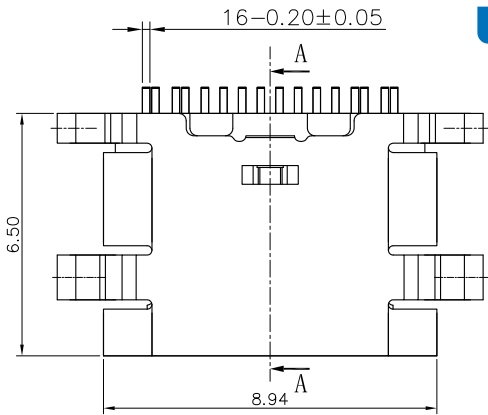

SECTION B-B
SCALE 1:1

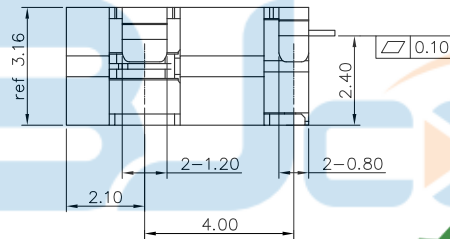
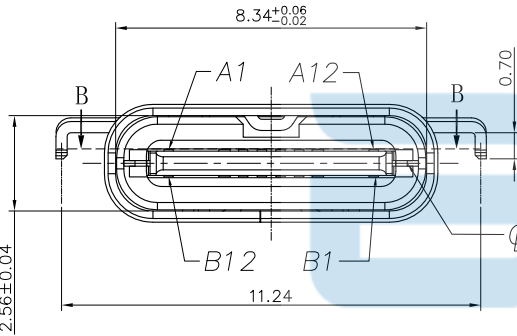

SECTION A-A
SCALE 1:1

NOTE:

- 1.MATERIAL SPECIFICATION:
 - 1.HOUSING: HIGH TEMPERATURE RESISTANT PLASTIC,UL94 V-0.
 - 2.CONTACTS: COPPER ALLOY
 - 3.MID PLATE: STAINLESS STEEL
- 2.PLATING SPECIFICATION:
 - 2-1.CONTACTS:
Ni 50u" MIN. UNDER PLATED OVER ALL.
Au PLATED ON THE FUNCTIONAL AREA OF CONTACT.
GOLD FLASH PLATING ON SOLDER AREA
 - 2-2. SHELL:
Ni 30u" MIN. UNDER PLATED OVER ALL.
- 3.MECHANICAL PERFORMANCE,
 - 3-1.INSERTION FORCE: 0.5~2.0kgf.
 - 3-2.REMOVAL FORCE: 0.8kgf~2.0kgf.
 - 3-3.DURABILITY: 10000 CYCLES.
- 4.ELECTRICAL PERFORMANCE,
 - 4-1. CURRENT RATING: 5A
VOLTAGE RATING: 20V
 - 4-2.INSULATION RESISTANCE: 100MΩ MIN
 - 4-3.DIELECTRIC WITHSTAND VOLTAGE,AC 100V FOR 1 MINUTE.
 - 4-4.LOW CONTACT RESISTANCE: INITIAL 40MΩ
AFTER 50MΩ
5. ENVIRONMENTAL PERFORMANCE:

OPERATING TEMPERATURE: -30°C~+80°C.
- 6.IR REFLOW:

THE PEAK TEMPERATURE ON THE BOARD SHALL BE MAINTAINED FOR 10 SECONDS AT 260°C.

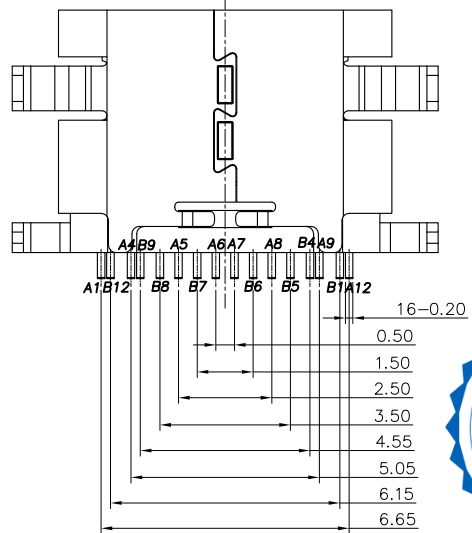

TOLERANCE UNSPECIFIED	
.0	±0.35
.00	±0.25
.000	±0.15
X. °	±2.00°
CUSTOMER DRAWING	

深圳市步步精科技有限公司

TITLE: TYPE-C 16P 母座L=6.5沉板2.4 (CH=0.82mm)

DRAWN/ DATE	设计 LYX	SIZE:A4	UNIT:MM.	PART. NO: UC.01.31-11-0014
CHECKED/ DATE	审核 HMY	SCALE: 1:1	PROJECTION	REV.: 版本
APPROVED/ DATE	核准 LJP	DWG. PATH	0100-2	SHEET: 页码

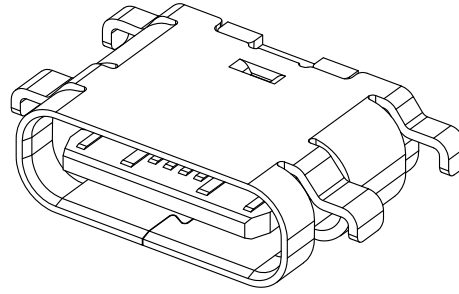

REV.	DESCRIPTION	NAME	DATE
A	NEWS ISSUE		

USB TYPE-C PIN ASSIGNMENTS

PIN NUMBER	SIGNAL NAME
A1	GND
A4	VBUS
A5	CC1
A6	Dp1
A7	Dn1
A8	SBU1
A9	VBUS
A12	GND

PIN NUMBER	SIGNAL NAME
B12	GND
B9	VBUS
B8	SBU2
B7	Dn2
B6	Dp2
B5	CC2
B4	VBUS
B1	GND

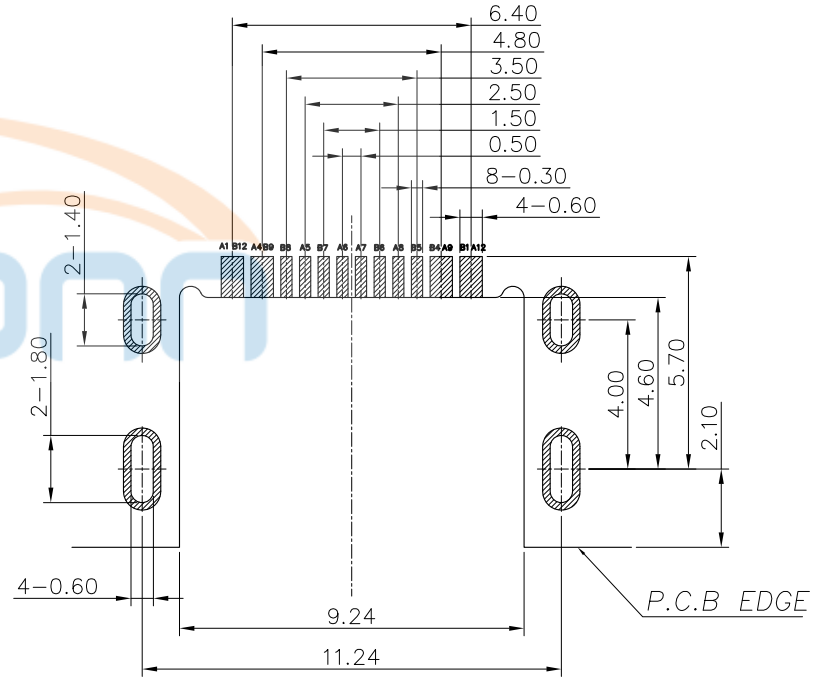

RECOMMEND P.C.B LAYOUT(COMPONENT SIDE)
TOLERANCE FOR PCB LAYOUT IS ± 0.05



TOLERANCE UNSPECIFIED		深圳市步步精科技有限公司 TITLE: TYPE-C 16P 母座L=6.5沉板2.4 (CH=0.82mm)					
.0	± 0.35						
.00	± 0.25	DRAWN/ DATE	设计 LYX	SIZE:A4	UNIT:MM.	PART. NO: UC.01.31-11-0014	
.000	± 0.15	CHECKED/ DATE	审核 HMY	SCALE: 1:1		PROJECTION	REV.: 版本
X.°	$\pm 2.00^\circ$	APPROVED/ DATE	核准 LJP	DWG. PATH	0100-2		SHEET: 页码
CUSTOMER DRAWING							



REV.	DESCRIPTION	NAME	DATE
A	NEWS ISSUE		

出料方向
PULL OUT DIRECTEON

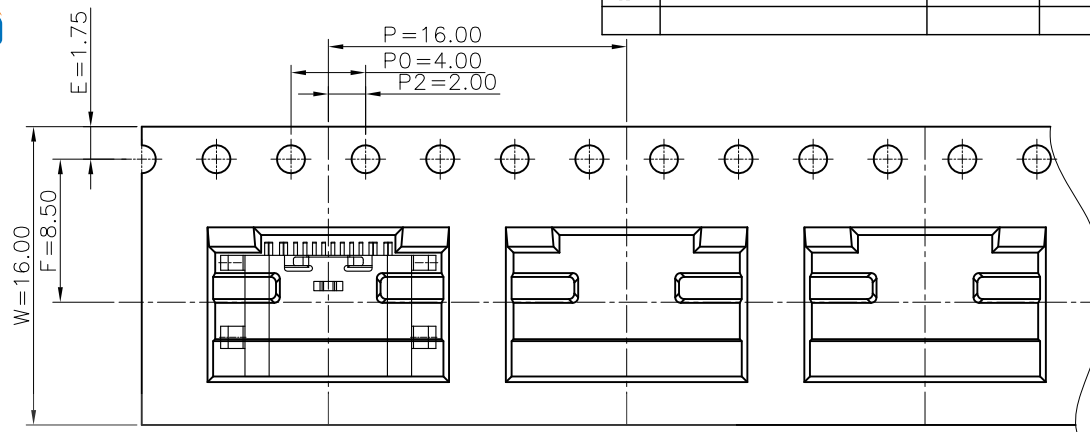
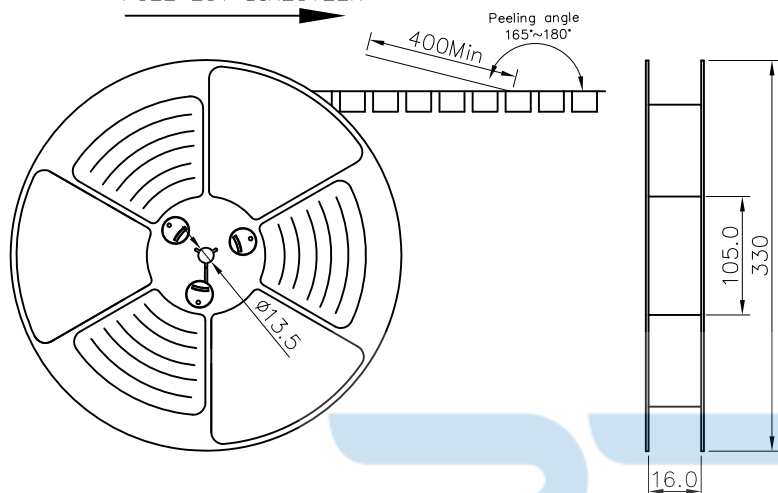

NOTES

1. 帶子引導長度
LEAD TAPE LENGTH

出料方向
PULL OUT DIRECTEON

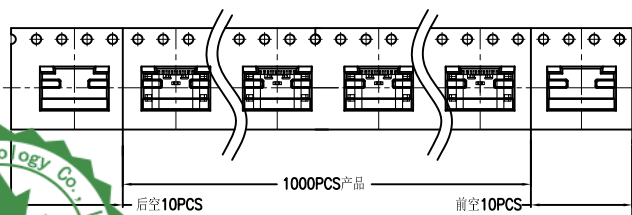

TAPE & REEL 14 PCS
1 REEL = 1000 PCS

BOX
DIMENSIONS:
33.5X33.5X30.5

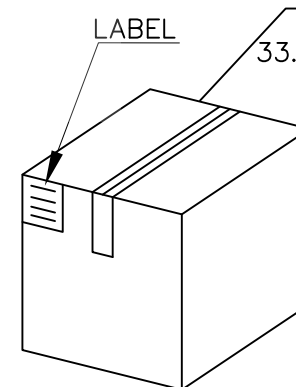
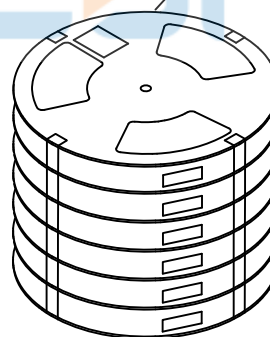

1 CARTON = 14 REELS = 14000 PCS



2. 帶子剝離力為: 0.1~1.3N(10.2gf~130gf)
PEELING OFF FORCE OF TOP TAPE: 0.1~1.3N(10.2gf~130gf)

出貨運輸過程中一定注意:
THIS REQUIREMENT SHOULD BE APPLIED AT SHIPMENT:
卷帶在運輸過程中不能散開
PEELING OFF SHOULD NOT BE ALLOWED DURING TRANSPORTATION



TOLERANCE UNSPECIFIED

.0	±0.35
.00	±0.25
.000	±0.15
X. °	±2.00°

CUSTOMER DRAWING

深圳市步步精科技有限公司

TITLE: TYPE-C 16P 母座L=6.5沉板2.4 (CH=0.82mm)

包裝明細表 (The detail of the packing) Carton						
產品料號 (Product No.)	包裝容量 (Packing Capacity)			重量 Weight (Kg)		
	pcs/box	boxes/Carton	Pcs/Box	N.W./Pcs	N.W./Box	G.W./Box
	1000	14	14000	----	----	----

DRAWN/ DATE	设计 LYX	SIZE:A4	UNIT:MM.	PART.NO: UC.01.31-11-0014
CHECKED/ DATE	审核 HMY	SCALE: 1:1	PROJECTION	REV.: 版本
APPROVED/ DATE	核准 LJP	DWG. PATH	0100-2	SHEET: 页码