



REV.	DESCRIPTION	NAME	DATE
A	NEWS ISSUE		

NOTE:

- MATERIAL SPECIFICATION:**
 - HOUSING: HIGH TEMPERATURE RESISTANT PLASTIC, UL94 V-0(LCP)
 - CONTACTS: COPPER ALLOY(C2680)
 - MID-PLATED: STAINLESS STEEL(SUS301)
- PLATING SPECIFICATION:**
 - CONTACTS:
 - Ni 50u" MIN. UNDER PLATED OVER ALL.
 - Au PLATED ON THE FUNCTIONAL AREA OF CONTACT.
 - GOLD FLASH PLATING ON SOLDER AREA
 - FRONT SHELL:
 - Ni 30u" MIN. UNDER PLATED OVER ALL.
- MECHANICAL PERFORMANCE,**
 - INSERTION FORCE: 0.5~2.0kgf.
 - REMOVAL FORCE: 0.8kgf~2.0kgf.
 - DURABILITY: 10000 CYCLES.
- ELECTRICAL PERFORMANCE,**
 - CURRENT RATING: 5.0A
VOLTAGE RATING: 20V
 - INSULATION RESISTANCE: 100MΩ MIN
 - DIELECTRIC WITHSTAND VOLTAGE, AC 100V FOR 1 MINUTE.
 - LOW CONTACT RESISTANCE: INITIAL 40MΩ /AFTER 50MΩ
- ENVIRONMENTAL PERFORMANCE:**

OPERATING TEMPERATURE: -30°C~+80°C.
- IR REFLOW:**

THE PEAK TEMPERATURE ON THE BOARD SHALL BE MAINTAINED FOR 10 SECONDS AT 260°C.

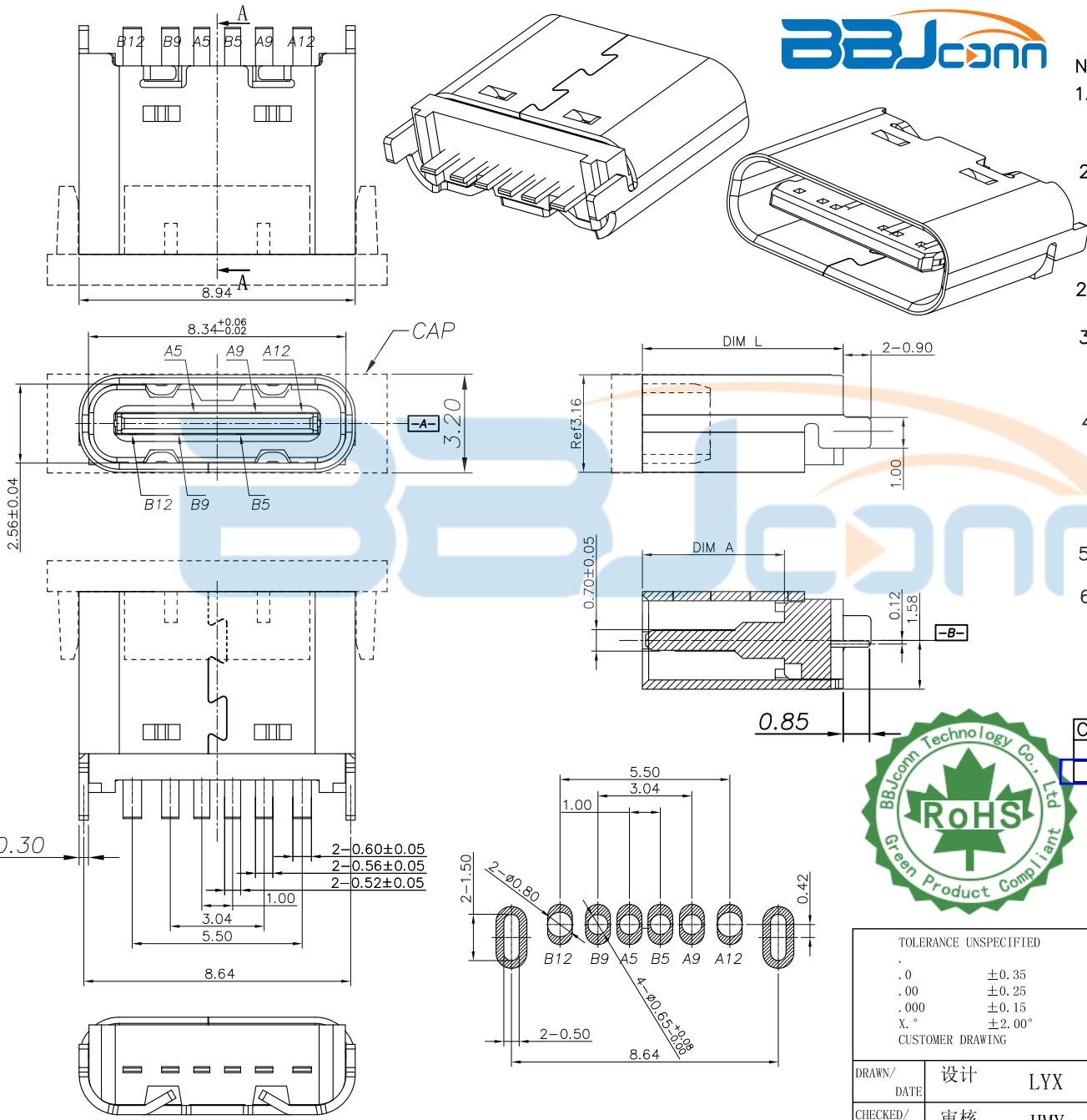

Code	DIM L	DIM A
0	6.80	4.90
1	6.50	4.60



USB TYPE-C PIN ASSIGNMENTS

PIN NUMBER	SIGNAL NAME
A5	CC1
A9	VBUS
A12	GND
B12	GND
B9	VBUS
B5	CC2

TOLERANCE UNSPECIFIED		深圳市步步精科技有限公司	
.0	±0.35	TITLE: TYPE-C 6P 母座直立式H=6.50端子 (DIP) 带中夹片	
.00	±0.25	DRAWN/ DATE: 设计 LYX	SIZE: A4 UNIT: MM. PART. NO: UC.01.63-11-0007
.000	±0.15	CHECKED/ DATE: 审核 HMY	SCALE: 1:1 PROJECTION
X.°	±2.00°	APPROVED/ DATE: 核准 LJP	DWG. PATH: 0100-2
CUSTOMER DRAWING		REV.: 版本	
		SHEET: 页码	

RECOMMEND P.C.B LAYOUT (COMPONENT SIDE)

TOLERANCE FOR PCB LAYOUT IS ± 0.05



REV.	DESCRIPTION	NAME	DATE
A	NEWS ISSUE		

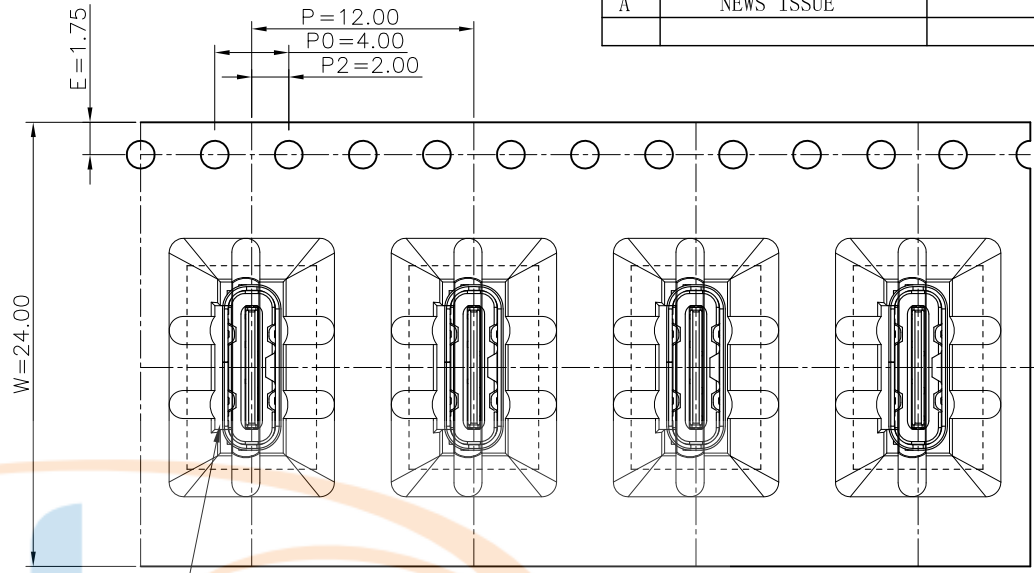
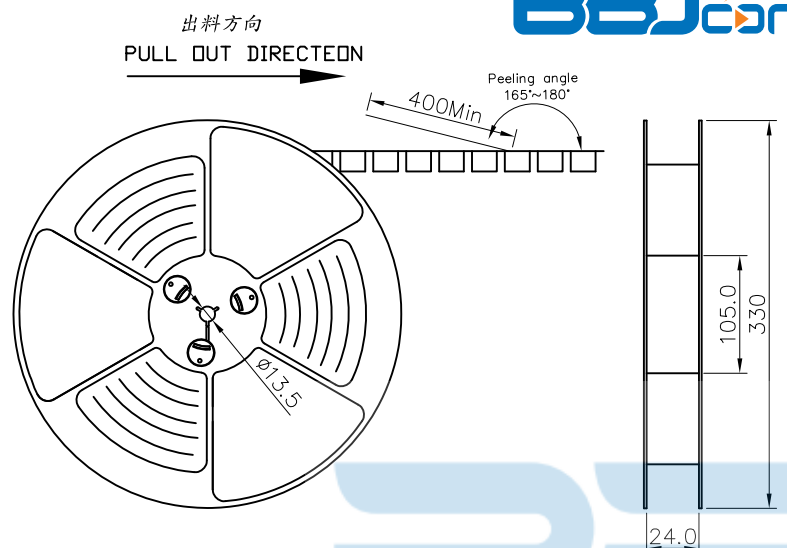

NOTES

1. 帶子引導長度
LEAD TAPE LENGTH
 出料方向
PULL OUT DIRECTEON
- 出料方向
PULL OUT DIRECTEON

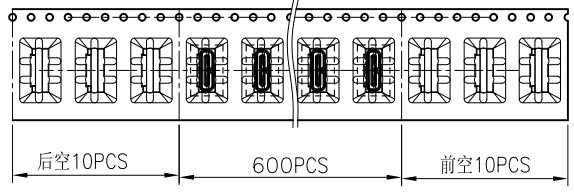

2. 上帶 剝力力為：0.1~1.3N(10.2gf~130gf)
PEELING OFF FORCE OF TOP TAPE:0.1~1.3N(10.2gf~130gf)
 出貨運輸過程中一定注意：
THIS REQUIREMENT SHOULD BE APPLIED AT SHIPMENT：
 卷帶在運輸過程中不能散開
PEELING OFF SHOULD NOT BE ALLOWED DURING TRANSPORTATION

焊腳插左

TAPE & REEL 10 PCS

BOX

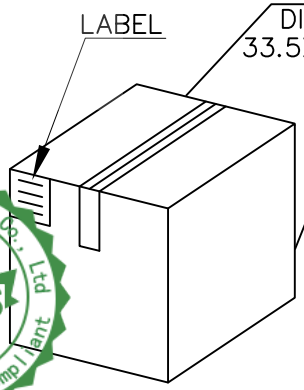
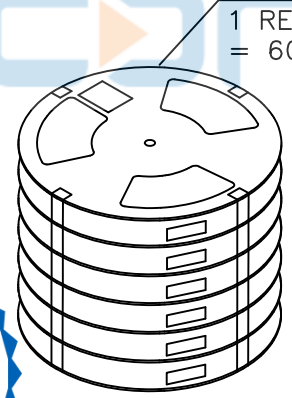

1 CARTON
 =10 REELS
 =6000 PCS



TOLERANCE UNSPECIFIED	
.0	±0.35
.00	±0.25
.000	±0.15
X.°	±2.00°
CUSTOMER DRAWING	

深圳市步步精科技有限公司

TITLE: TYPE-C 6P 母座直立式H=6.50端子 (DIP) 帶中夾片

包裝明細表 (The detail of the packing) Carton						
產品料號 (Product No.)	包裝容量 (Packing Capacity)			重量 Weight (Kg)		
	pcs/box	boxs/Carton	Pcs/Box	N.W./Pcs	N.W./Box	G.W./Box
	600	10	6000	----	----	----

DRAWN/ DATE	设计 LYX	SIZE:A4	UNIT:MM.	PART. NO: UC.01.63-11-0007
CHECKED/ DATE	审核 HMY	SCALE: 1:1	PROJECTION	REV.: 版本
APPROVED/ DATE	核准 LJP	DWG. PATH	0100-2	SHEET: 页码