

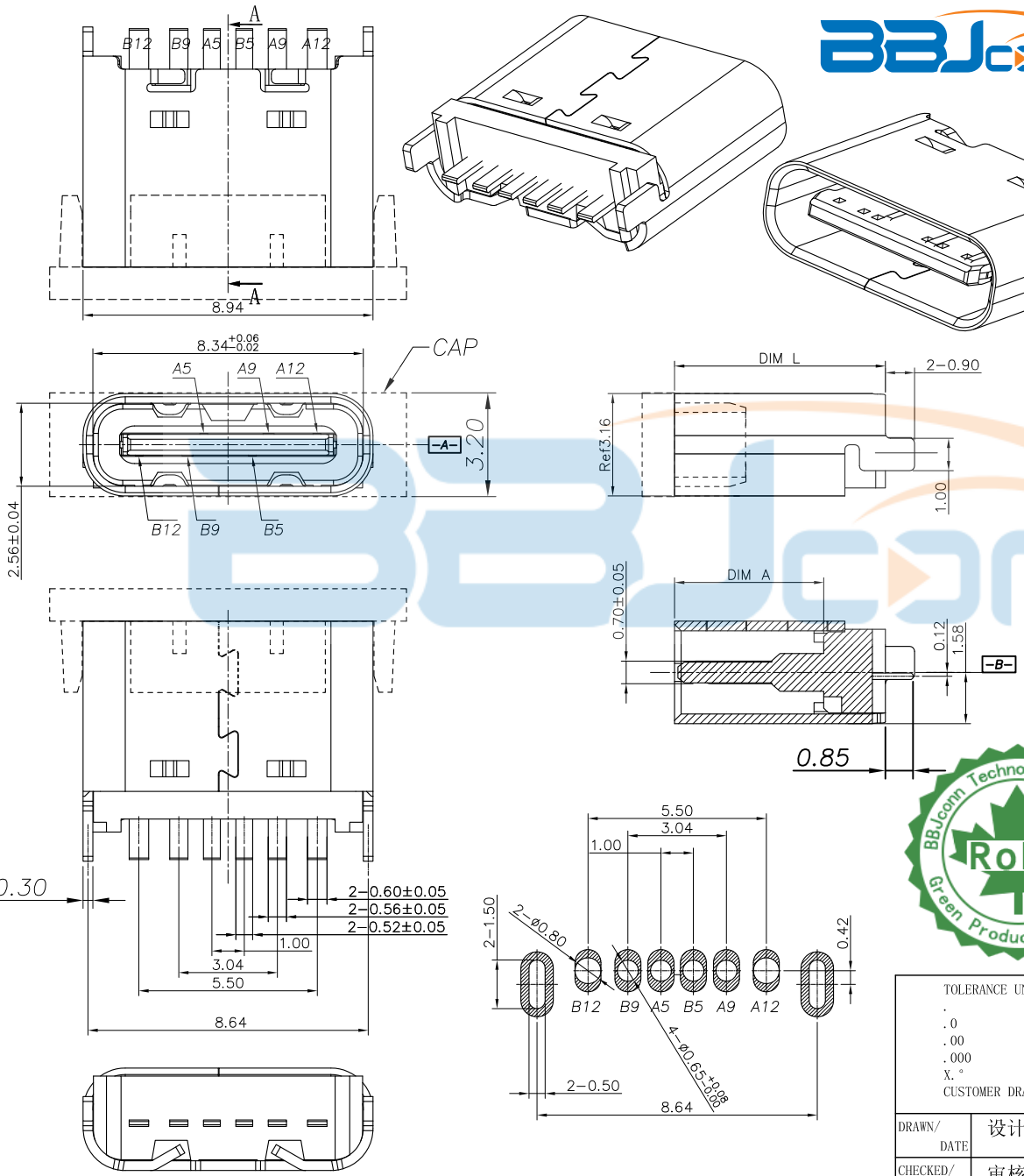

REV.	DESCRIPTION	NAME	DATE
A	NEWS ISSUE		

**NOTE:**

- MATERIAL SPECIFICATION:**
  - HOUSING: HIGH TEMPERATURE RESISTANT PLASTIC, UL94 V-0(LCP).
  - CONTACTS: COPPER ALLOY(C2680)
  - MID-PLATED: STAINLESS STEEL(SUS301)
- PLATING SPECIFICATION:**
  - CONTACTS:**  
Ni 50u" MIN. UNDER PLATED OVER ALL.  
Au PLATED ON THE FUNCTIONAL AREA OF CONTACT.  
GOLD FLASH PLATING ON SOLDER AREA
  - FRONT SHELL:**  
Ni 30u" MIN. UNDER PLATED OVER ALL.
- MECHANICAL PERFORMANCE,**
  - INSERTION FORCE: 0.5~2.0kgf.
  - REMOVAL FORCE: 0.8kgf~2.0kgf.
  - DURABILITY: 10000 CYCLES.
- ELECTRICAL PERFORMANCE,**
  - CURRENT RATING: 5.0A  
VOLTAGE RATING: 20V
  - INSULATION RESISTANCE: 100MΩ MIN
  - DIELECTRIC WITHSTAND VOLTAGE, AC 100V FOR 1 MINUTE.
  - LOW CONTACT RESISTANCE: INITIAL 40MΩ /AFTER 50MΩ
- ENVIRONMENTAL PERFORMANCE:**  
OPERATING TEMPERATURE: -30°C~+80°C.
- IR REFLOW:**  
THE PEAK TEMPERATURE ON THE BOARD SHALL BE MAINTAINED FOR 10 SECONDS AT 260°C.



Code	DIM L	DIM A
0	6.80	4.90
1	6.50	4.60



**USB TYPE-C PIN ASSIGNMENTS**

PIN NUMBER	SIGNAL NAME
A5	CC1
A9	VBUS
A12	GND
B12	GND
B9	VBUS
B5	CC2

**RECOMMEND P.C.B LAYOUT (COMPONENT SIDE)**  
TOLERANCE FOR PCB LAYOUT IS ± 0.05

TOLERANCE UNSPECIFIED .0 ±0.35 .00 ±0.25 .000 ±0.15 X.° ±2.00° CUSTOMER DRAWING		<b>深圳市步步精科技有限公司</b>	
DRAWN/ DATE: 设计 LYX		SIZE: A4	UNIT: MM.
CHECKED/ DATE: 审核 HMY		PART. NO: UC.01.63-11-0006	PROJECTION:
APPROVED/ DATE: 核准 LJP		SCALE: 1:1	REV.: 版本
		DWG. PATH: 0100-2	SHEET: 页码



REV.	DESCRIPTION	NAME	DATE
A	NEWS ISSUE		

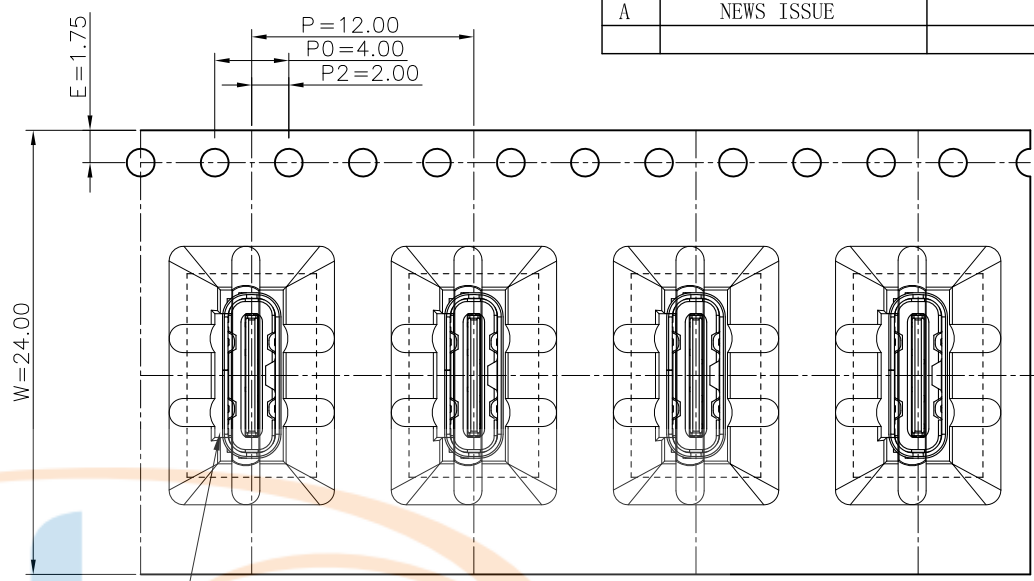
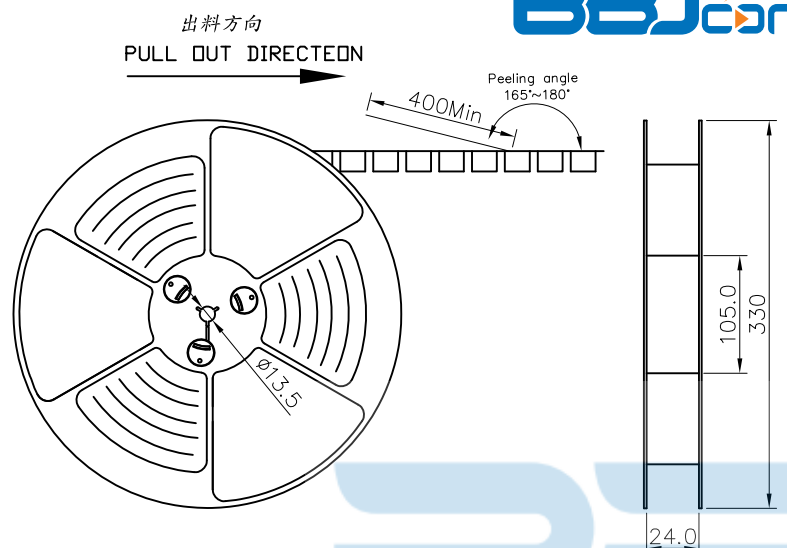

**NOTES**

1. 帶子引導長度  
LEAD TAPE LENGTH

出料方向 PULL OUT DIRECTEON  
出料方向 PULL OUT DIRECTEON

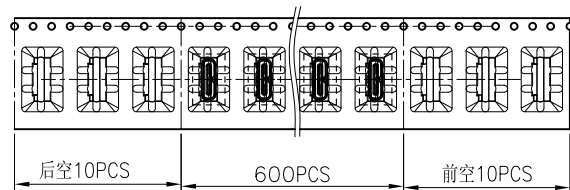

2. 上帶 剝力力為 : 0.1~1.3N(10.2gf~130gf)  
PEELING OFF FORCE OF TOP TAPE: 0.1~1.3N(10.2gf~130gf)

出貨運輸過程中一定注意：  
THIS REQUIREMENT SHOULD BE APPLIED AT SHIPMENT：  
卷帶在運輸過程中不能散開  
PEELING OFF SHOULD NOT BE ALLOWED DURING TRANSPORTATION

焊腳插左

TAPE & REEL 10 PCS

1 REEL  
= 600 PCS

BOX

DIMENSIONS:  
33.5X33.5X30.5

1 CARTON  
= 10 REELS  
= 6000 PCS

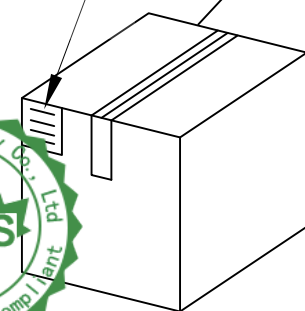
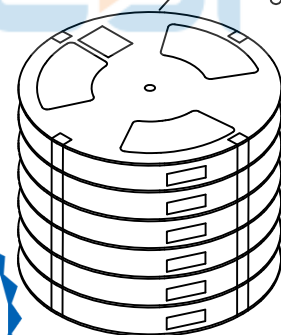

TOLERANCE UNSPECIFIED

.0	±0.35
.00	±0.25
.000	±0.15
X. °	±2.00°

CUSTOMER DRAWING

**深圳市步步精科技有限公司**

TITLE: TYPE-C 6P 母座直立式H=6.80端子 (DIP) 帶中夾片

包裝明細表 (The detail of the packing) Carton						
產品料號 (Product No.)	包裝容量 (Packing Capacity)			重量 Weight (Kg)		
	pcs/box	boxes/Carton	Pcs/Box	N.W./Pcs	N.W./Box	G.W./Box
	600	10	6000	----	----	----

DRAWN/ DATE	设计 LYX	SIZE:A4	UNIT:MM.	PART. NO:	UC.01.63-11-0006
CHECKED/ DATE	审核 HMY	SCALE: 1:1	PROJECTION	REV.:	版本
APPROVED/ DATE	核准 LJP	DWG. PATH	0100-2	SHEET:	页码