

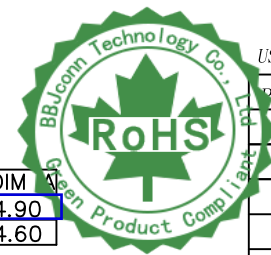

REV.	DESCRIPTION	NAME	DATE
A	NEWS ISSUE		

NOTE:

- MATERIAL SPECIFICATION:**
 - HOUSING: HIGH TEMPERATURE RESISTANT PLASTIC, UL94 V-0(LCP).
 - CONTACTS: COPPER ALLOY(C2680)
 - MID-PLATED: STAINLESS STEEL(SUS301)
- PLATING SPECIFICATION:**
 - CONTACTS:**
 - Ni 50u" MIN. UNDER PLATED OVER ALL.
 - Au PLATED ON THE FUNCTIONAL AREA OF CONTACT.
 - GOLD FLASH PLATING ON SOLDER AREA
 - Ni 30u" MIN. UNDER PLATED OVER ALL.
 - FRONT SHELL:**
- MECHANICAL PERFORMANCE,**
 - INSERTION FORCE: 0.5~2.0kgf.
 - REMOVAL FORCE: 0.8kgf~2.0kgf.
 - DURABILITY: 10000 CYCLES.
- ELECTRICAL PERFORMANCE,**
 - CURRENT RATING: 5.0A
VOLTAGE RATING: 20V
 - INSULATION RESISTANCE: 100MΩ MIN
 - DIELECTRIC WITHSTAND VOLTAGE, AC 100V FOR 1 MINUTE.
- ENVIRONMENTAL PERFORMANCE:**
OPERATING TEMPERATURE: -30°C~+80°C.
- IR REFLOW:**
THE PEAK TEMPERATURE ON THE BOARD SHALL BE MAINTAINED FOR 10 SECONDS AT 260°C.

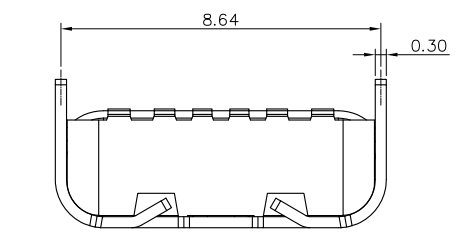
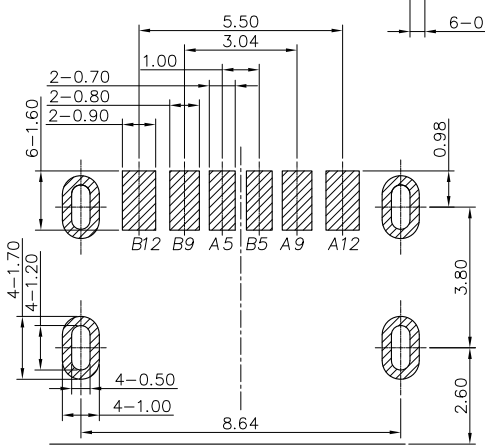
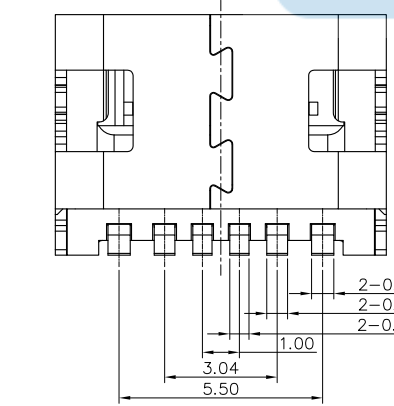
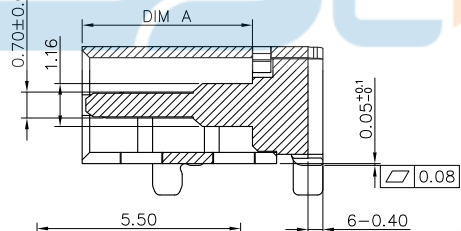
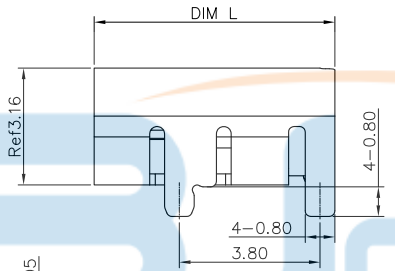
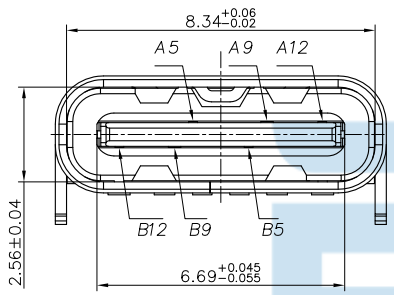
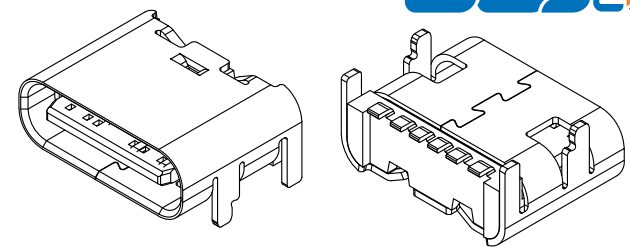
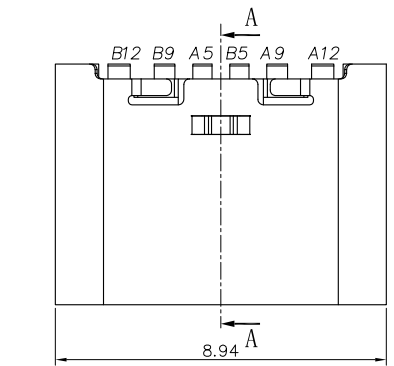

Code	DIM L	DIM A
0	6.80	4.90
1	6.50	4.60

USB TYPE-C PIN ASSIGNMENTS		
PIN NUMBER	SIGNAL NAME	
A5	CC1	
A9	VBUS	
A12	GND	
B12	GND	
B9	VBUS	
B5	CC2	

RECOMMEND P.C.B LAYOUT (COMPONENT SIDE)
TOLERANCE FOR PCB LAYOUT IS ± 0.05

TOLERANCE UNSPECIFIED .0 ±0.35 .00 ±0.25 .000 ±0.15 X. ° ±2.00° CUSTOMER DRAWING		深圳市步步精科技有限公司 TITLE: TYPE-C 6P 母座上四脚插L=6.8 CH1.63 带中夹片	
DRAWN/ DATE	设计 LYX	SIZE: A4	UNIT: MM.
CHECKED/ DATE	审核 HMY	PART. NO: UC.01.53-11-0010	SCALE: 1:1
APPROVED/ DATE	核准 LJP	DWG. PATH	PROJECTION
		0100-2	REV.: 版本
			SHEET: 页码



REV.	DESCRIPTION	NAME	DATE
A	NEWS ISSUE		

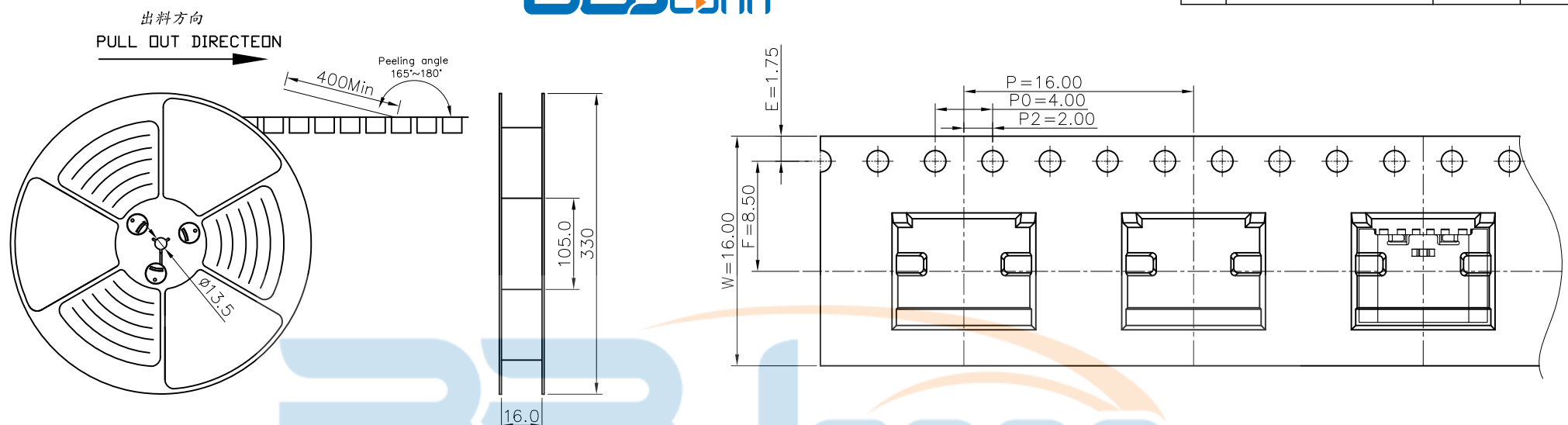

NOTES

1. 帶子引導長度
LEAD TAPE LENGTH
 出料方向
PULL OUT DIRECTEON

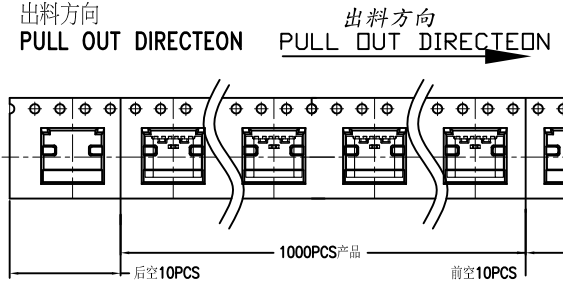

2. 上帶 剝力力為 : 0.1~1.3N(10.2gf~130gf)
PEELING OFF FORCE OF TOP TAPE:0.1~1.3N(10.2gf~130gf)
 出貨運輸過程中一定注意 :
THIS REQUIREMENT SHOULD BE APPLIED AT SHIPMENT :
 卷帶在運輸過程中不能散開
PEELING OFF SHOULD NOT BE ALLOWED DURING TRANSPORTATION

TAPE & REEL 14 PCS
 1 REEL = 1000 PCS

BOX
 DIMENSIONS:
 33.5X33.5X30.5

1 CARTON
 =14 REELS
 =14000 PCS

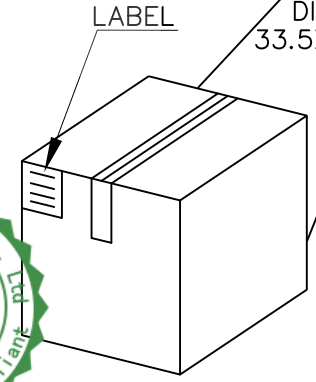
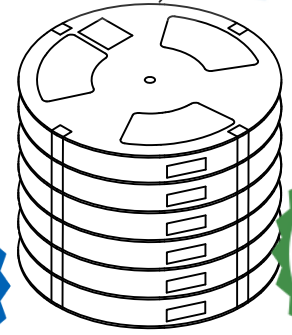

TOLERANCE UNSPECIFIED

.0	±0.35
.00	±0.25
.000	±0.15
X. °	±2.00°

CUSTOMER DRAWING

BBJconn 深圳市步步精科技有限公司

TITLE: TYPE-C 6P 母座板上四脚插L=6.8 CH1.63 帶中夾片

包裝明細表 (The detail of the packing) Carton

產品料號 (Product No.)	包裝容量 (Packing Capacity)			重量 Weight (Kg)		
	pcs/box	boxes/Carton	Pcs/Box	N.W./Pcs	N.W./Box	G.W./Box
	1000	14	14000	----	----	----

DRAWN/ DATE	设计 LYX	SIZE:A4	UNIT:MM.	PART.NO: UC.01.53-11-0010
CHECKED/ DATE	审核 HMY	SCALE: 1:1	PROJECTION	REV.: 版本
APPROVED/ DATE	核准 LJP	DWG. PATH	0100-2	SHEET: 页码